

Characterization and on-sky testing of high-resolution photonic, AWG-based astronomical spectrographs

Jerónimo Calderón-Gómez*¹, Frantz Martinache¹, Nick Cvetojević¹, Marc-Antoine Martinod¹, Vincent Foriel¹, Nemanja Jovanovic², Pradip Gatkine³, Gregory Sercel², Alexis Carlotti⁴, Marc Ferlet⁴, Matteo Pasinetti⁵, Angélie Alagao⁵, Arnaud Striffling⁵, Guillermo Martin⁴, David Mary¹, Roxanne Ligi¹, Sylvie Robbe-Dubois¹.

¹ **Université Côte d'Azur, Observatoire de la Côte d'Azur, CNRS, Laboratoire Lagrange**, Nice, France

² **Department of Astronomy, California Institute of Technology**, Pasadena, USA

³ **Department of Physics & Astronomy, University of California, Los Angeles (UCLA)**, Los Angeles, USA

⁴ **Université Grenoble Alpes, CNRS, IPAG**, Grenoble, France

⁵ **Aix Marseille Université, CNRS, LAM (Laboratoire d'Astrophysique de Marseille)**, Marseille, France

*: jcalderon@oca.eu

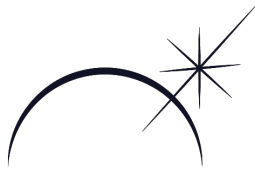

**OBSERVATOIRE
DE LA CÔTE D'AZUR**



UNIVERSITÉ CÔTE D'AZUR



Outline



1. Bulk optics vs photonics for spectroscopy
2. AWG spectrographs.
3. The *CoLiBRIS*-AWG spectrograph prototype at OCA/Lagrange.
 - a. In-lab Characterisation
 - b. On-sky testing at OHP
4. Preliminary results



Macaulay Library - F. Oñate

1. Bulk optics vs photonics

Spectrographs are bulky

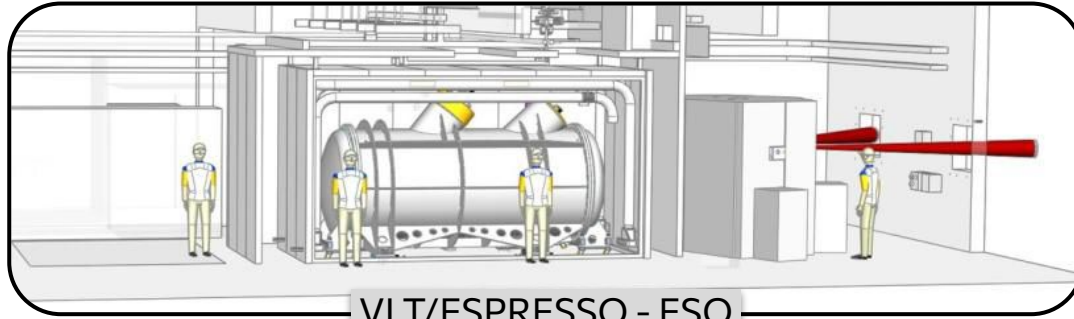

VLT/ESPRESSO - ESO

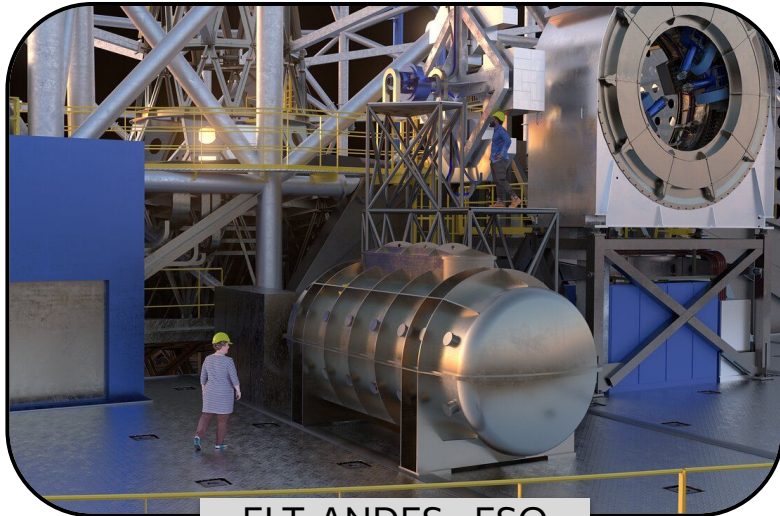

ELT-ANDES - ESO



JWST/NIRSpec - ESA+NASA



But do they have to be?

The astrophotonics approach allows for more **compact, stable, modular and reproducible** instruments!

Compact (photronics-based) Spectrographs!

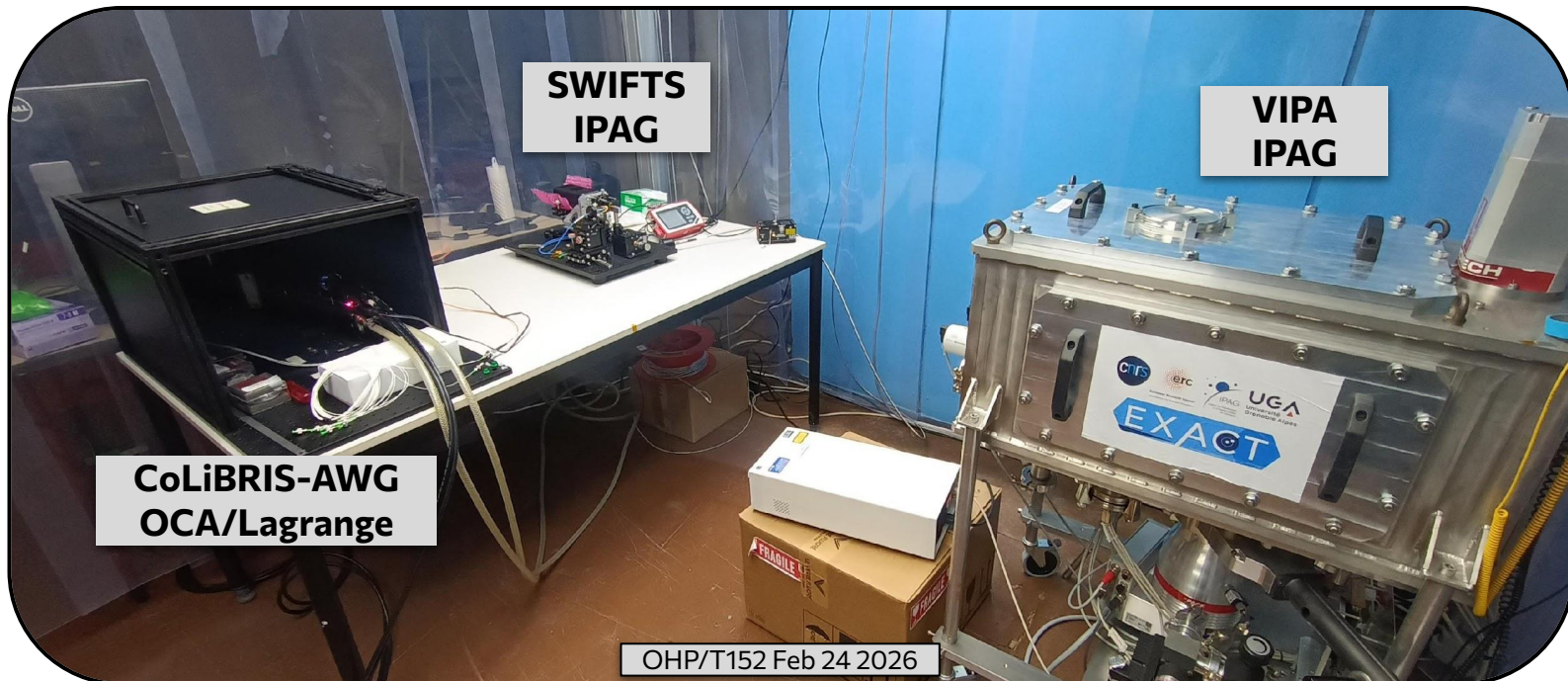



2. Arrayed Waveguide Gratings (AWGs)

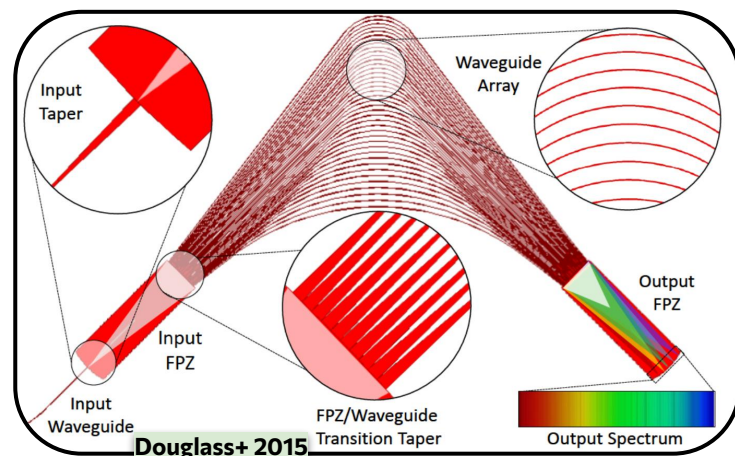
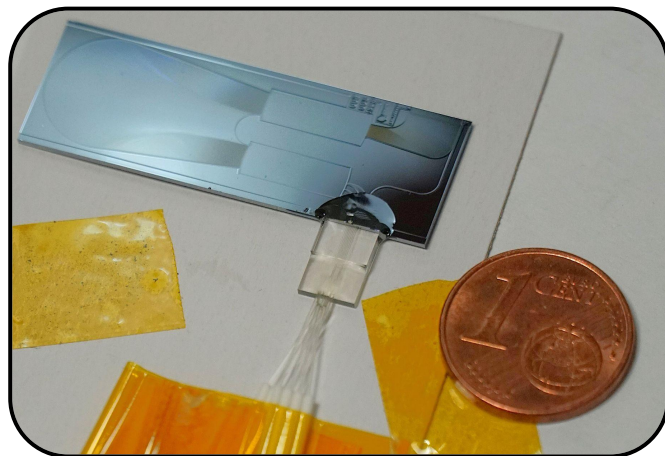
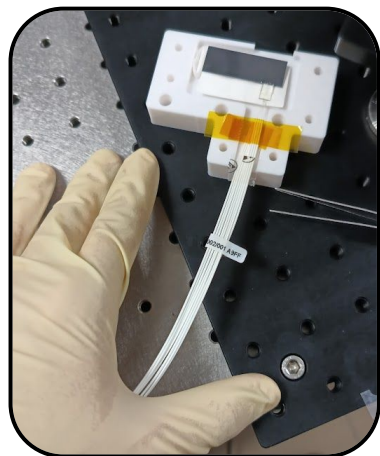

AWGs vs échelle gratings

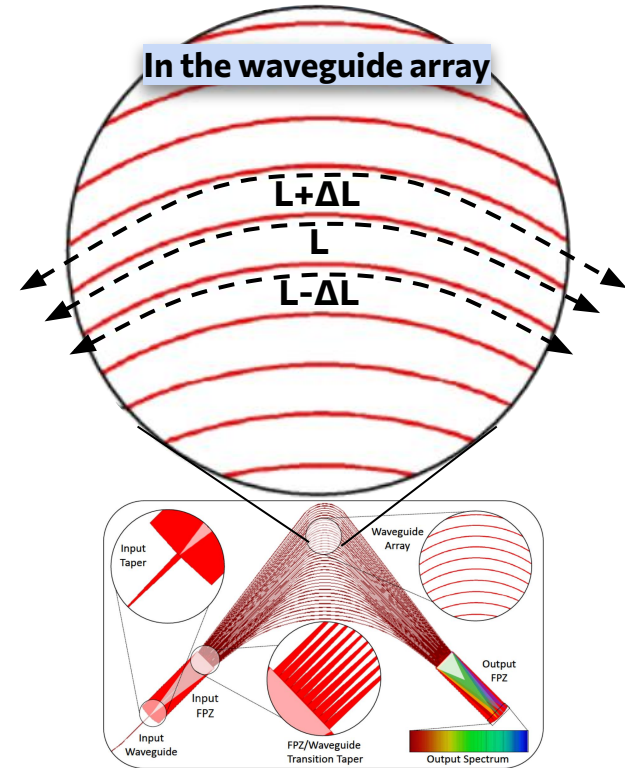
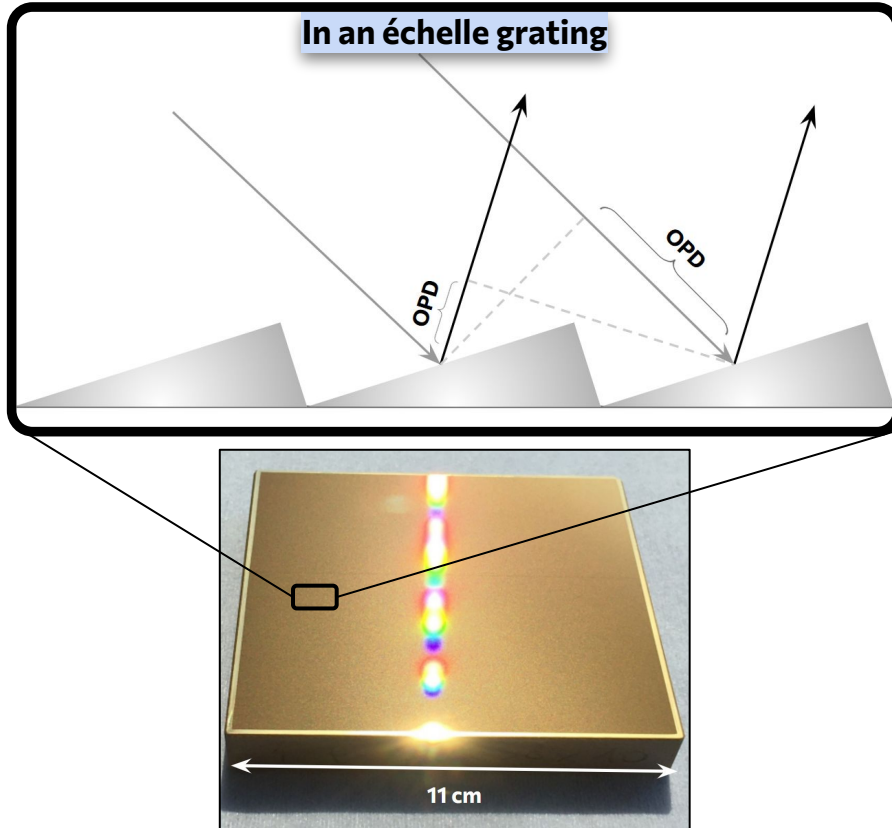

ΔL is chosen to optimize the dispersion around a reference wavelength

Light's journey inside the AWG chip

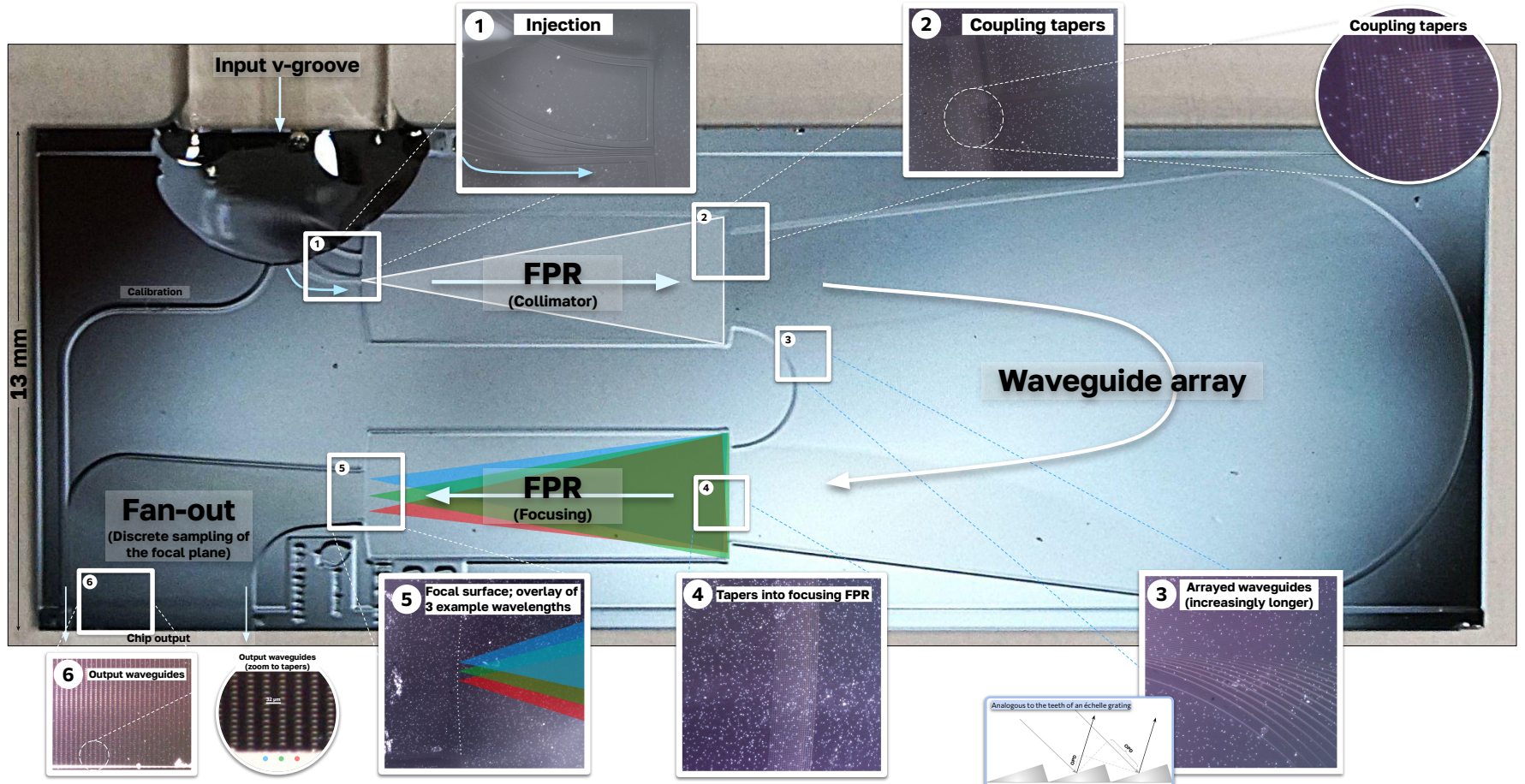

AWG-based spectrographs for astronomy

AWGs as main dispersers of **astronomical spectrographs!**
 Replacing bulky prisms/gratings with a chip of a few cm² of surface.

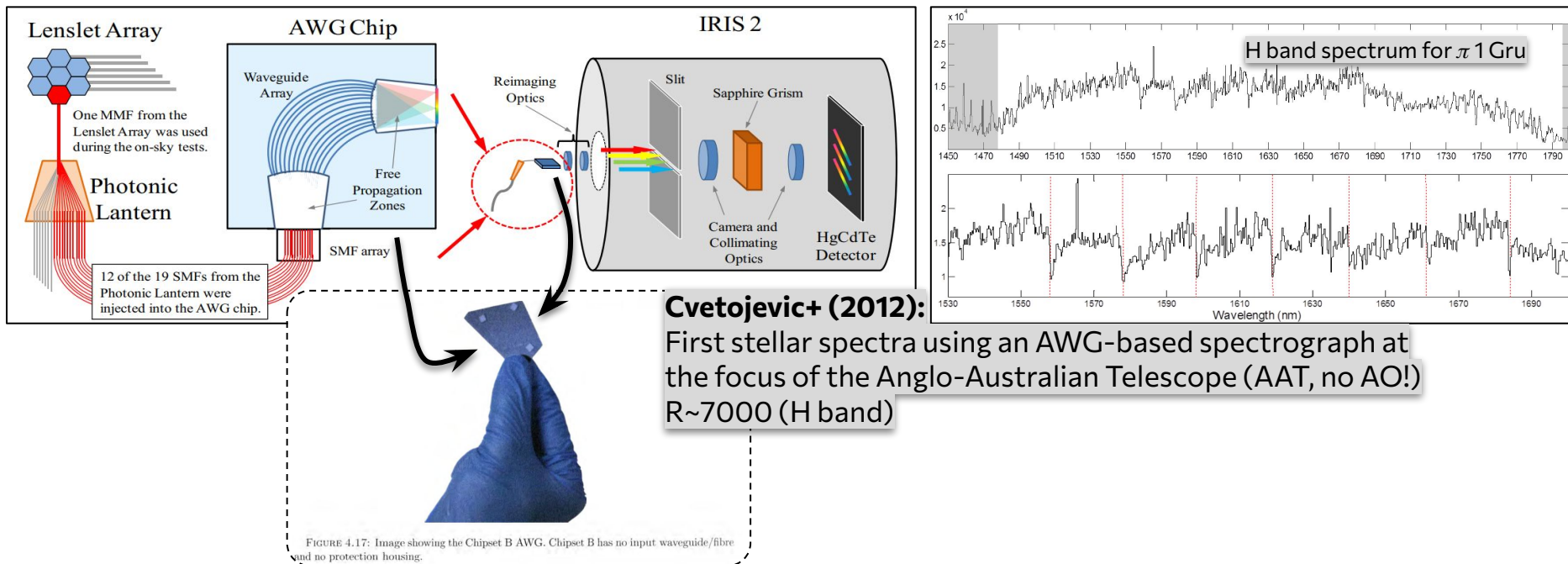



3. The **CoLiBRIS**-AWG spectrograph prototype at OCA/Lagrange.

Our prototype: CoLiBRIS-AWG

Compact **L**ightweight **B**roadband high-**R**esolution **I**nfrared **S**pectrographs - AWG

The setup is used to test different AWG chips. Currently two chips are in use:

- **Emerald (R~18000, H band)**, smaller chip.
- **Sapphire (R~36000, H band)**, larger chip.

The idea is to design new chips with more sophisticated applications of the AWGs.

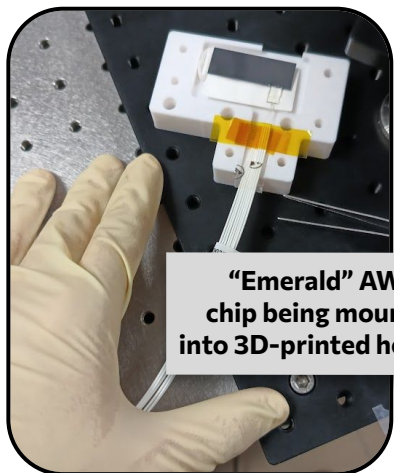

"Emerald" AWG chip being mounted into 3D-printed housing

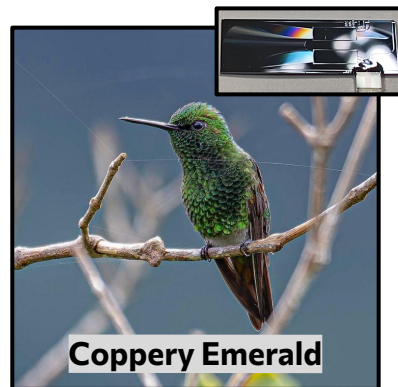

Coppery Emerald

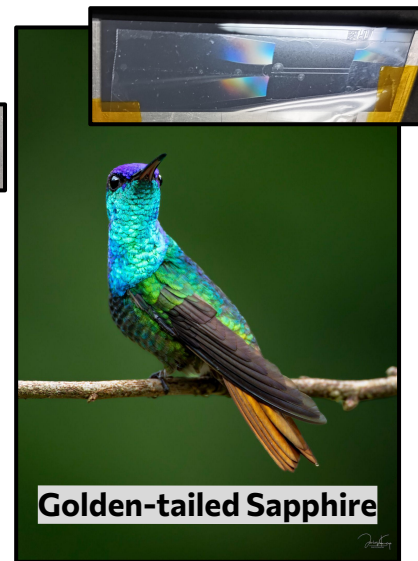

Golden-tailed Sapphire

Our prototype: CoLiBRIS-AWG

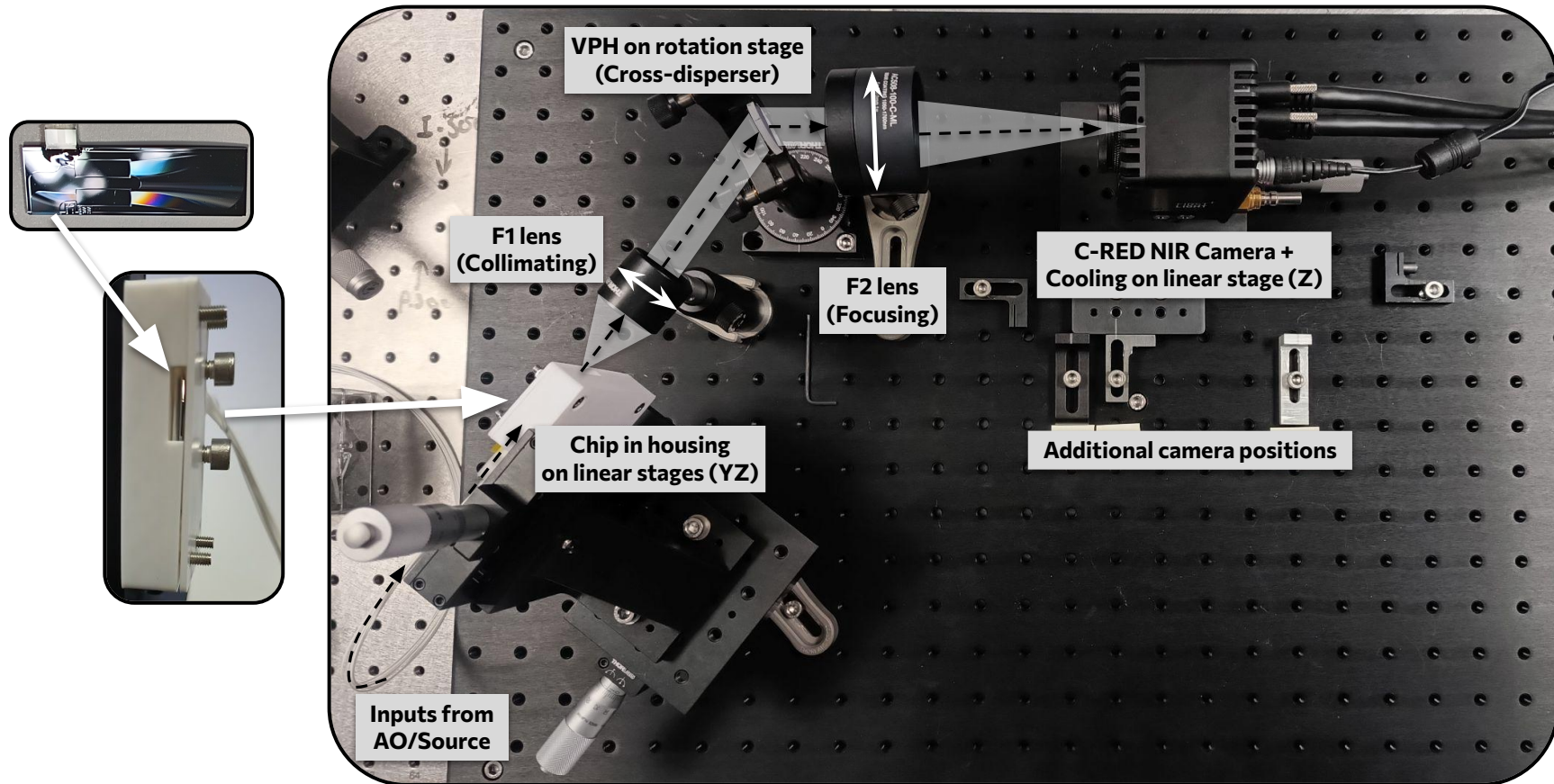

The datasets: AWG vs Straight-through channel

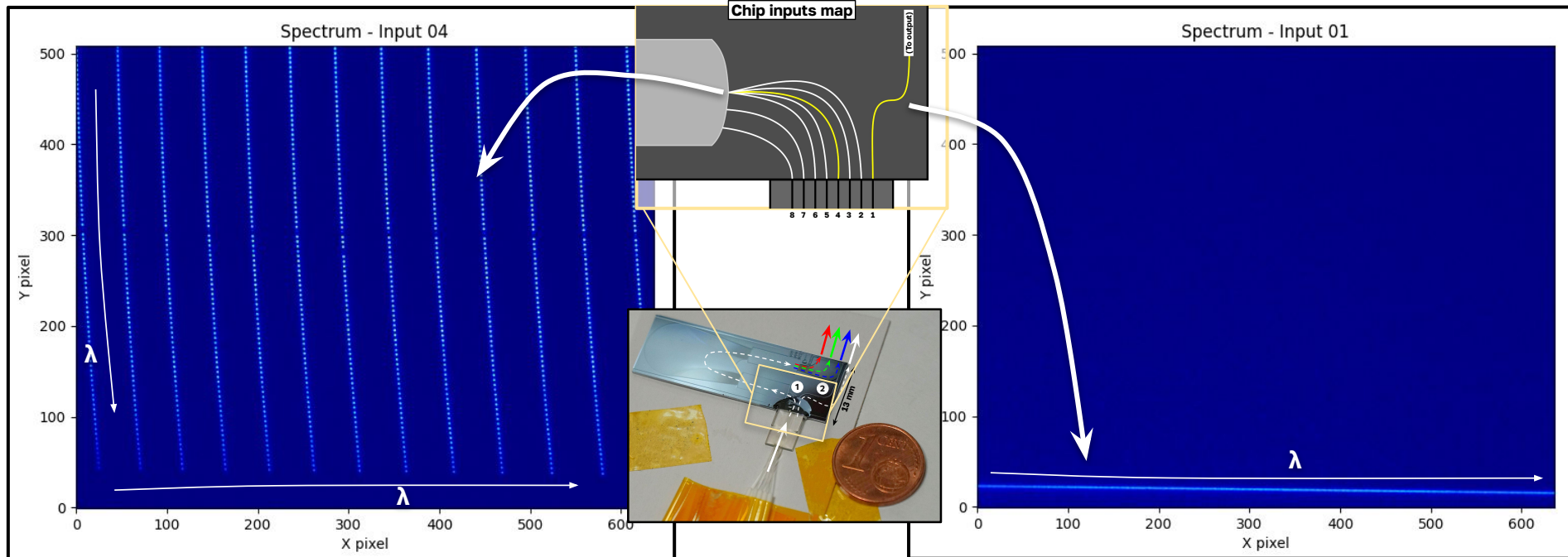

Setups for waveguide diagnostics, and measuring **spectral resolution ($R \sim 18000$)**, **throughput (TBD)** and spectral **coverage (1440–1630 nm)**.
Prototype used for on-sky tests at OHP/T152+PAPYRUS!

Multiple input tests

AWG spectrum, single input fed with broadband source, cross dispersed by VPH grating

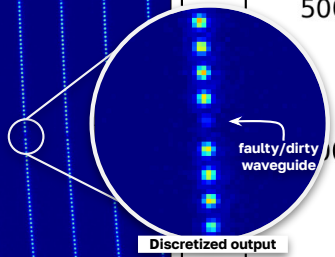
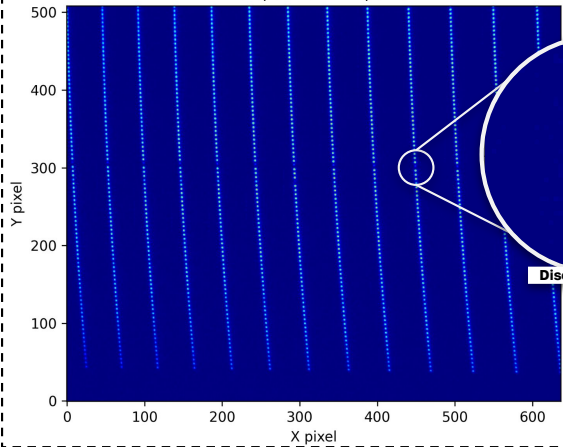

AWG spectra, multiple inputs fed with broadband source, cross dispersed by VPH grating

Stacked AWG spectra - Inputs 1, 4 and 7

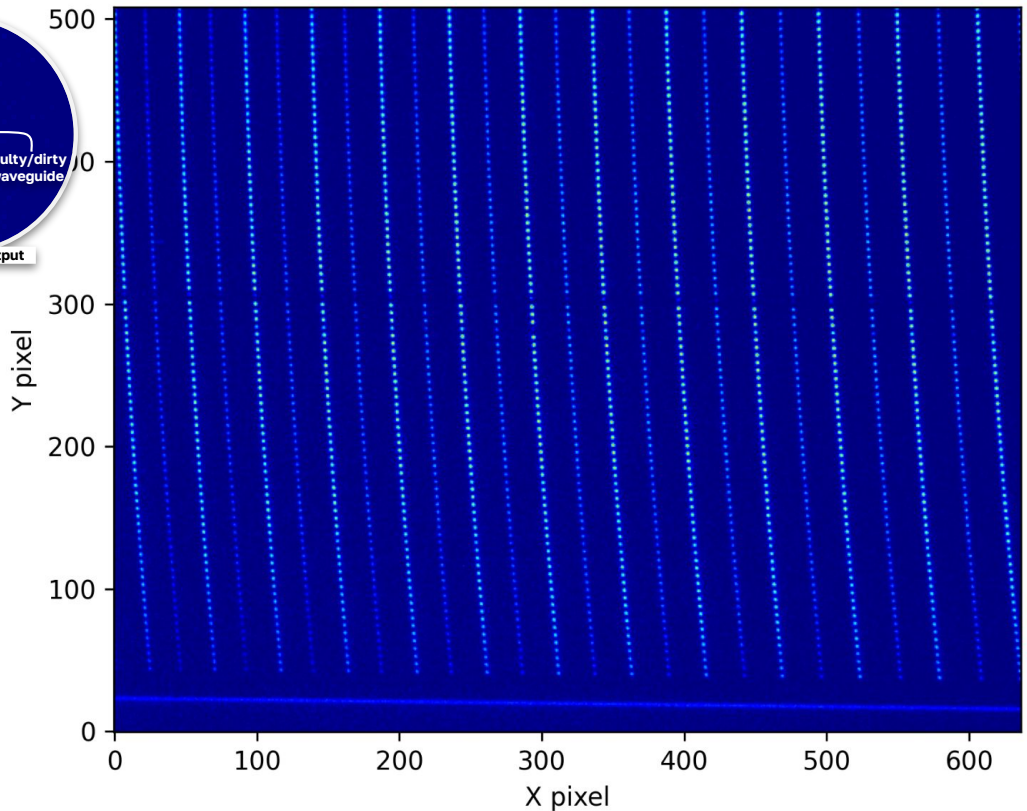

Chip inputs map

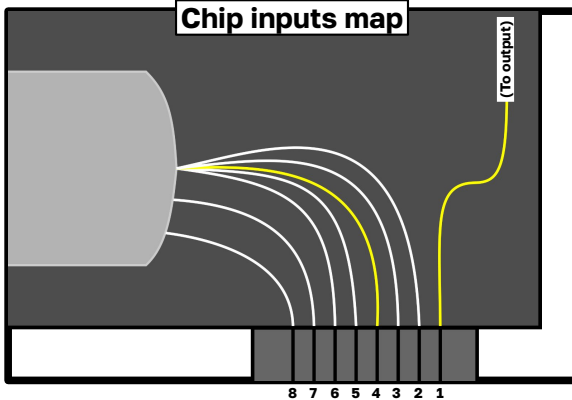



On-sky testing!

Observing run in **Feb 2026**

PEPR Origins - Compact Spectrographs Collaboration

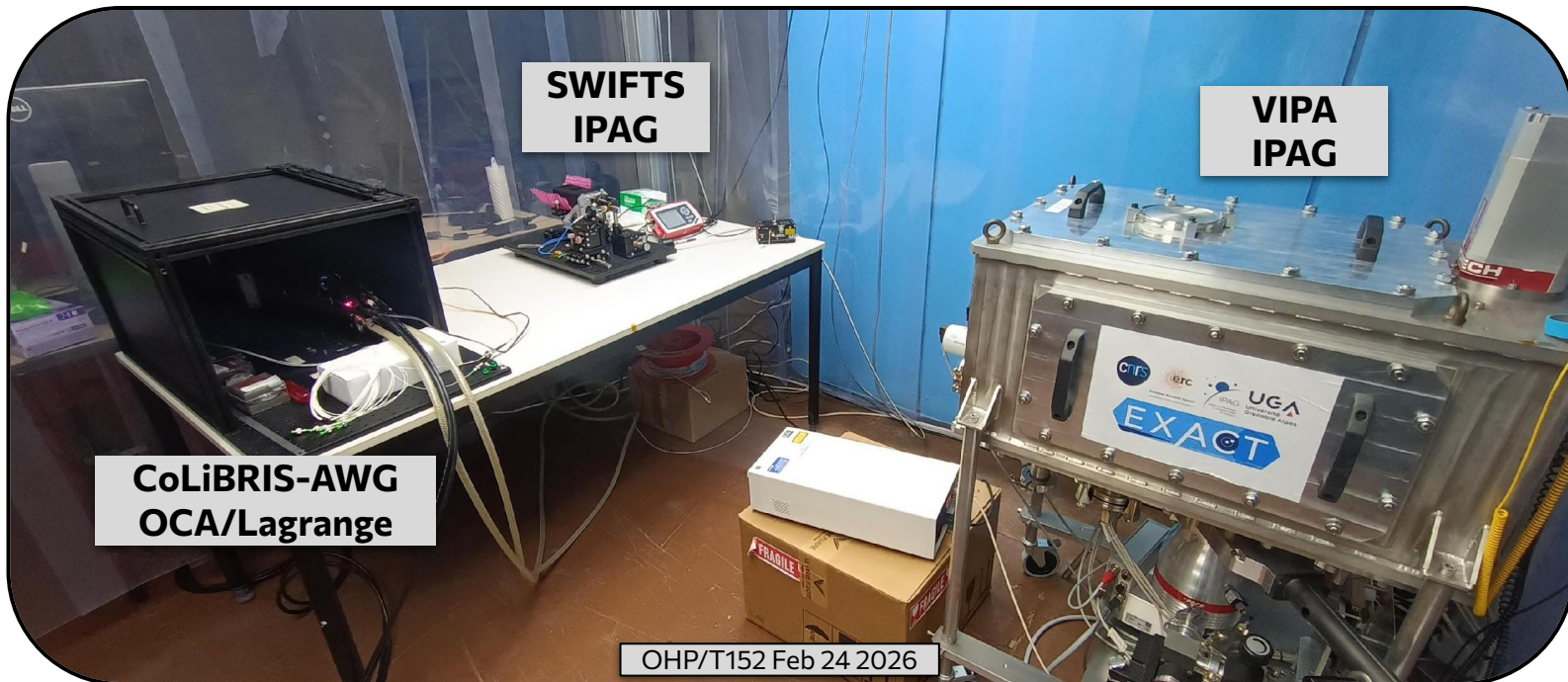

With **LAM** providing a common on-sky testing platform (e.g. the **PAPYRUS AO system**)

First Light observing run: OHP 24-26 Feb, 2026

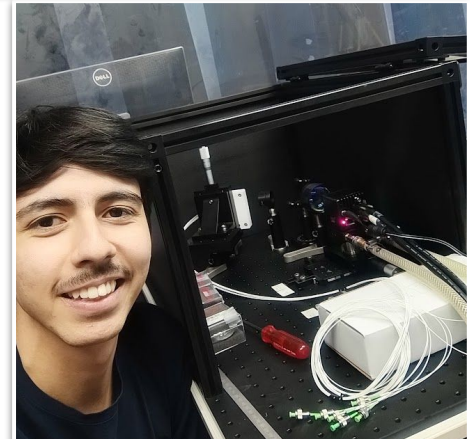
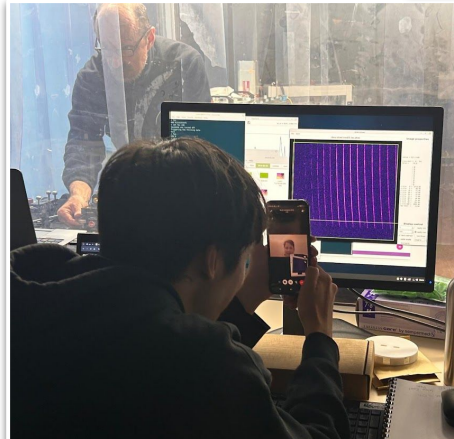
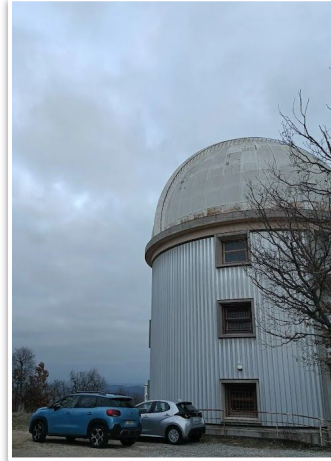
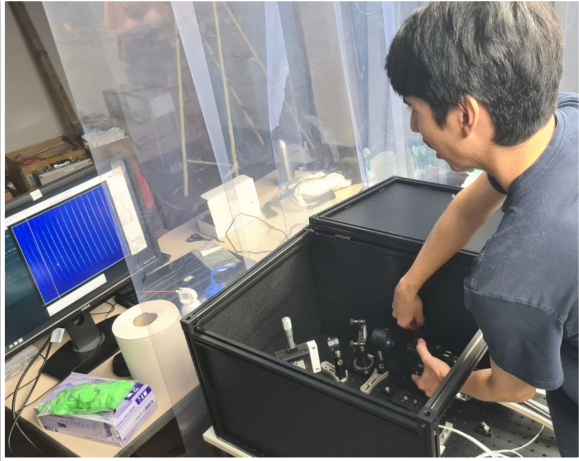



Macaulay Library - Anonymous

4. Preliminary results

First light

(images with each configuration taken separately and stacked for reference)

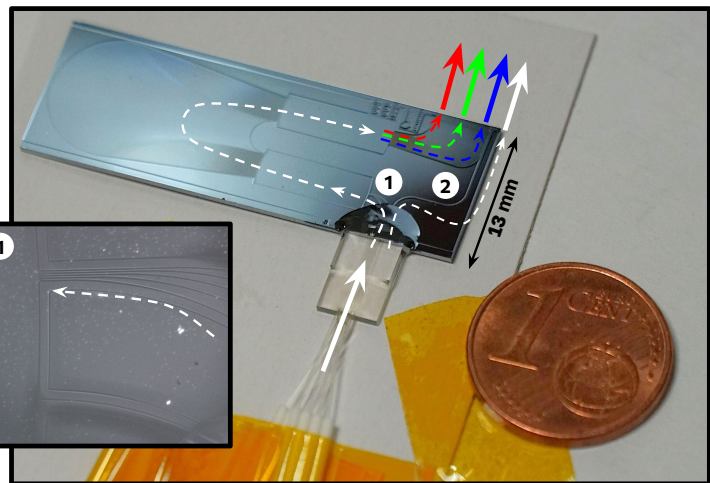
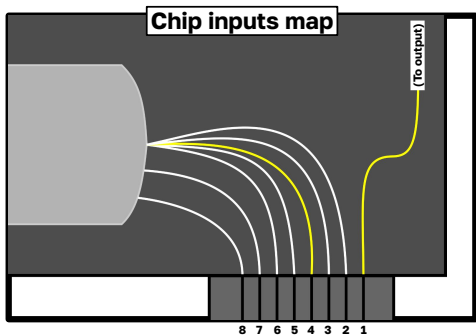

AWG & Straight-through spectra of Arcturus - 26/02/2026

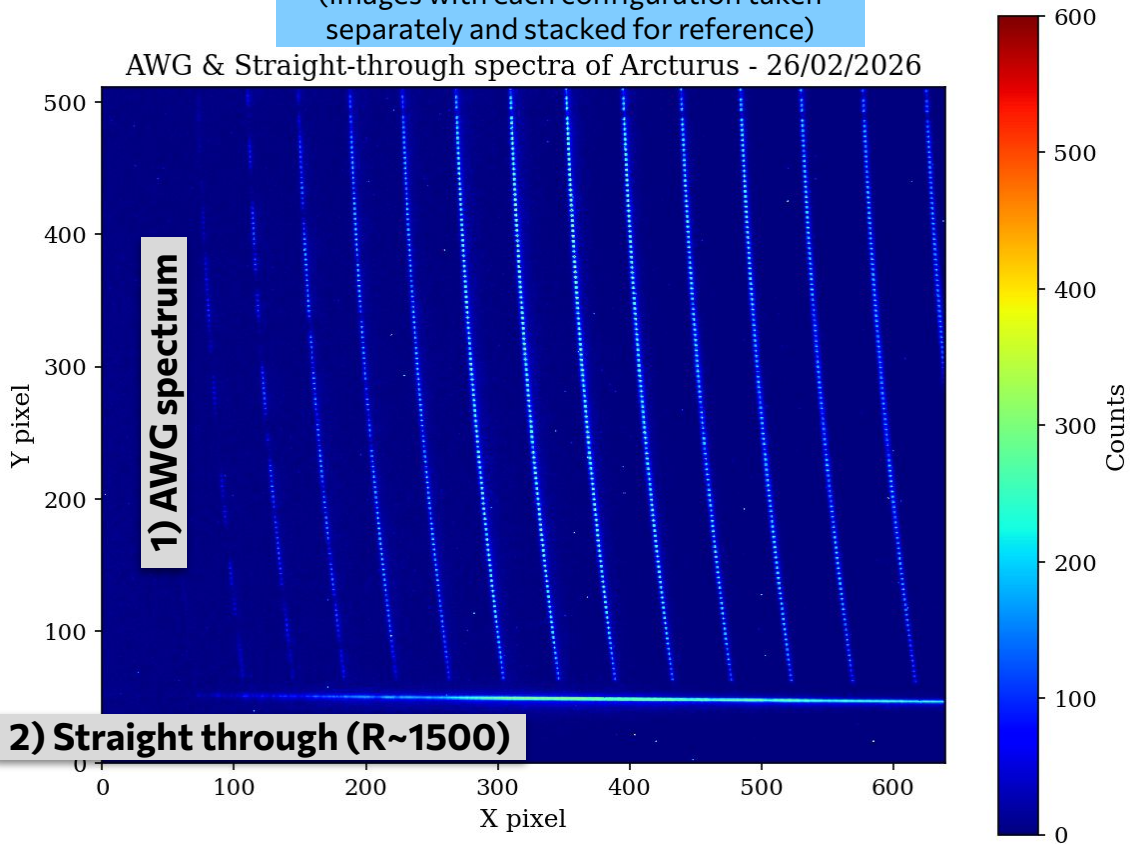

But first without the AWG: straight-through spectra

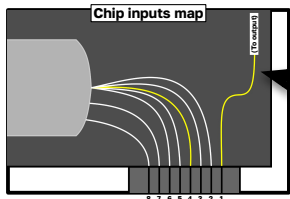

Input01 spectrum: Arcturus

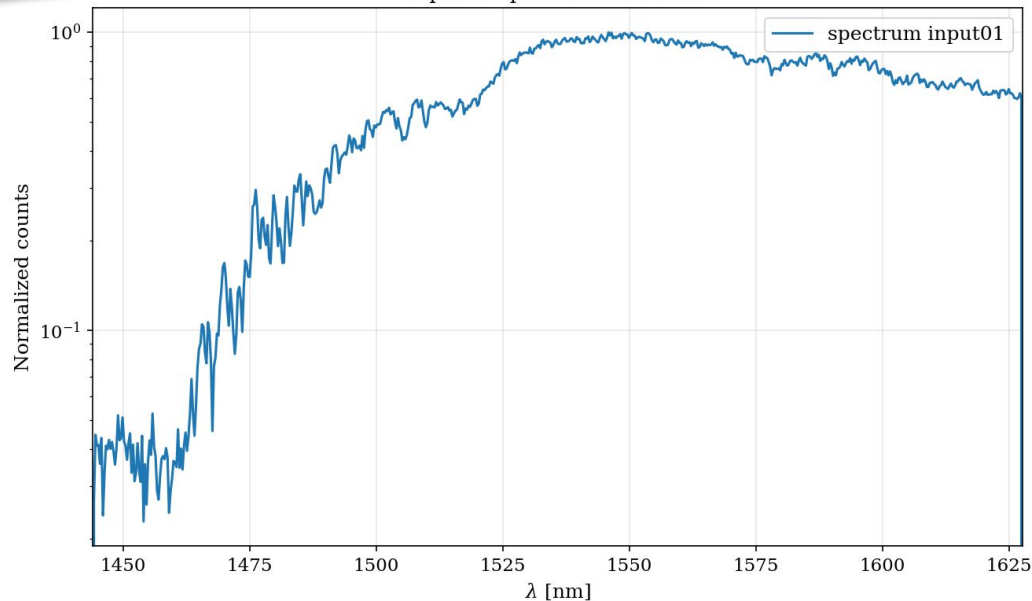

First light straight-thru spectrum of Arcturus 25/02/2026

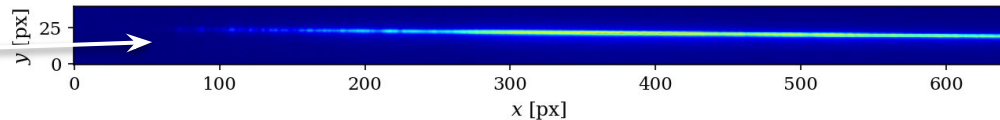
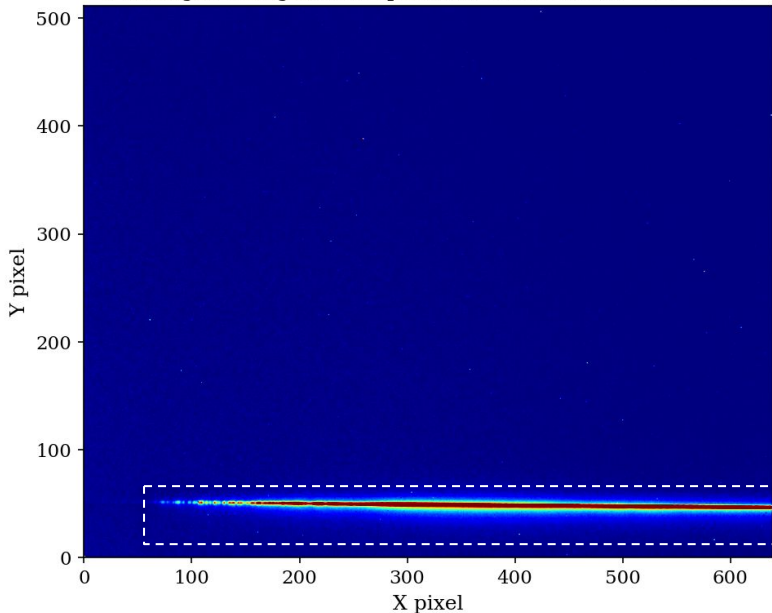

Input01 spectrum: Arcturus

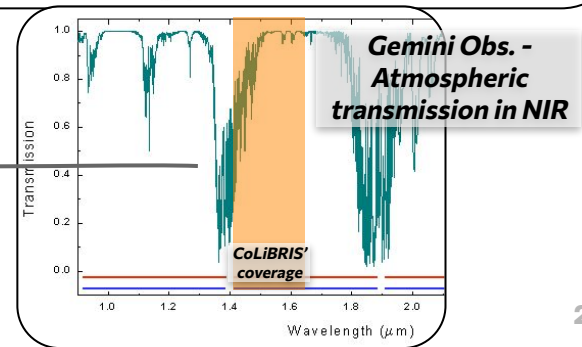
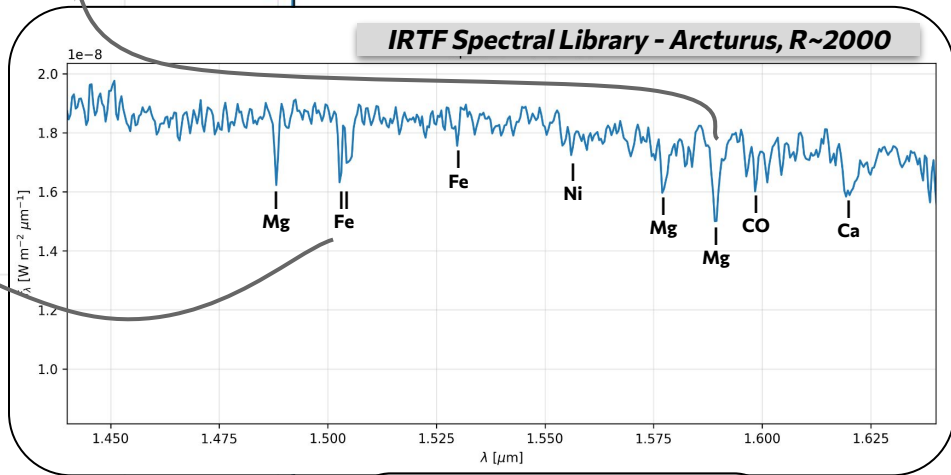
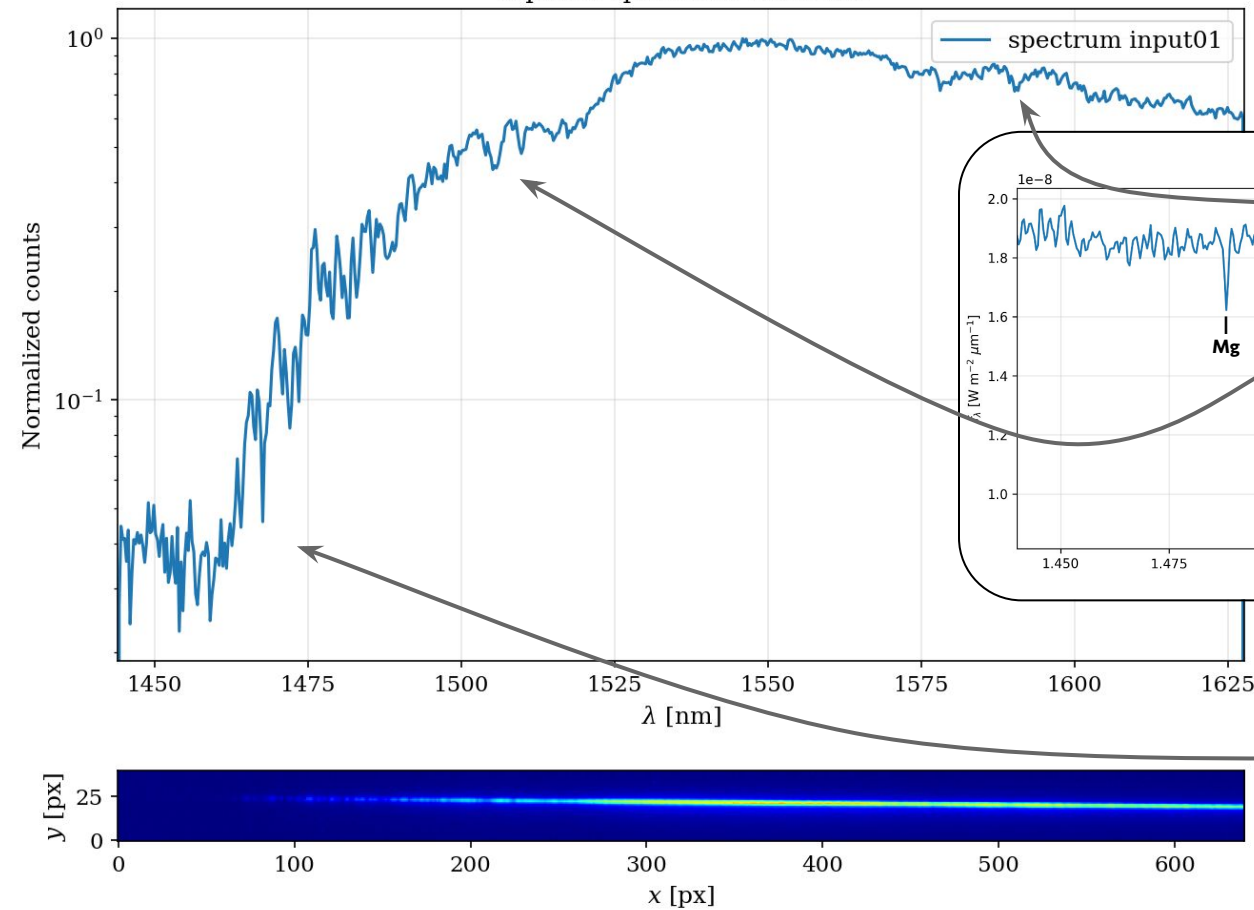

First analysis of the AWG spectra

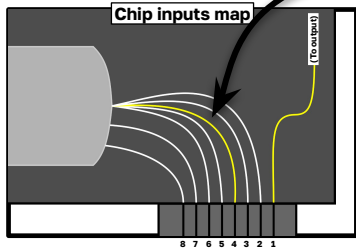

Mediandcorr. AWG spectrum of Arcturus - 26/02/2026 00-08-95

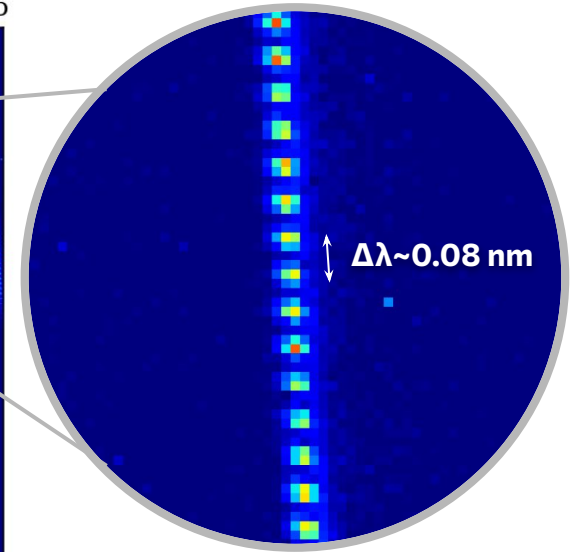
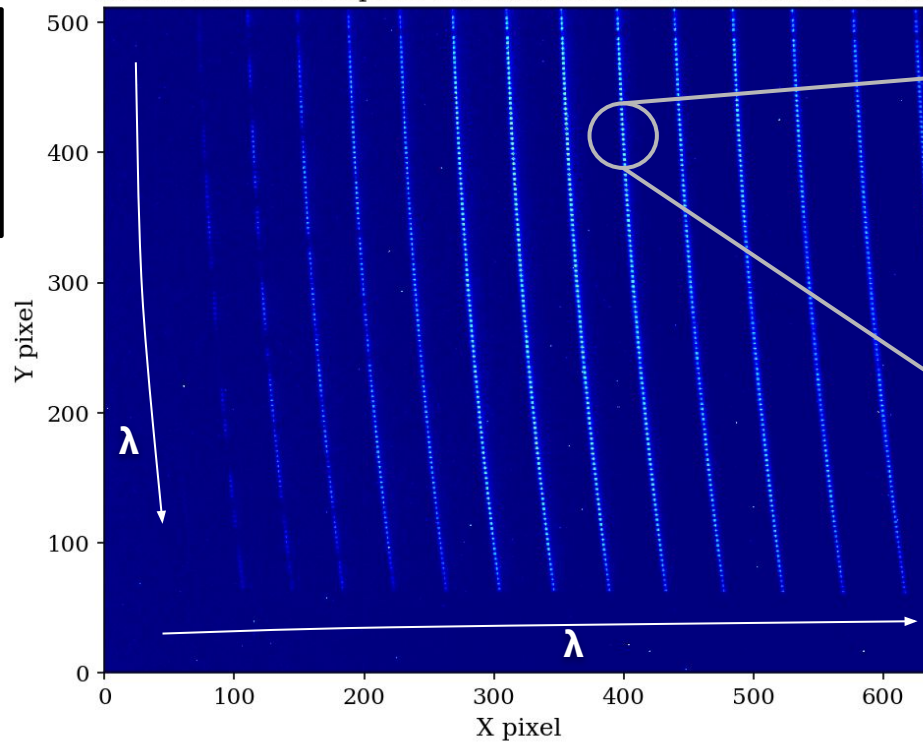

**Spectral Resolution: $R=18800$ at $\lambda=1562 \text{ nm}$
 ($\Delta\lambda$ between 2 adjacent waveguides $\sim 0.08 \text{ nm}$)**

Spectral coverage: 1444 nm to 1630 nm

Instrument response: Broadband source spectra



CoLiBRIS/Emerald - Instrument response to broadband source

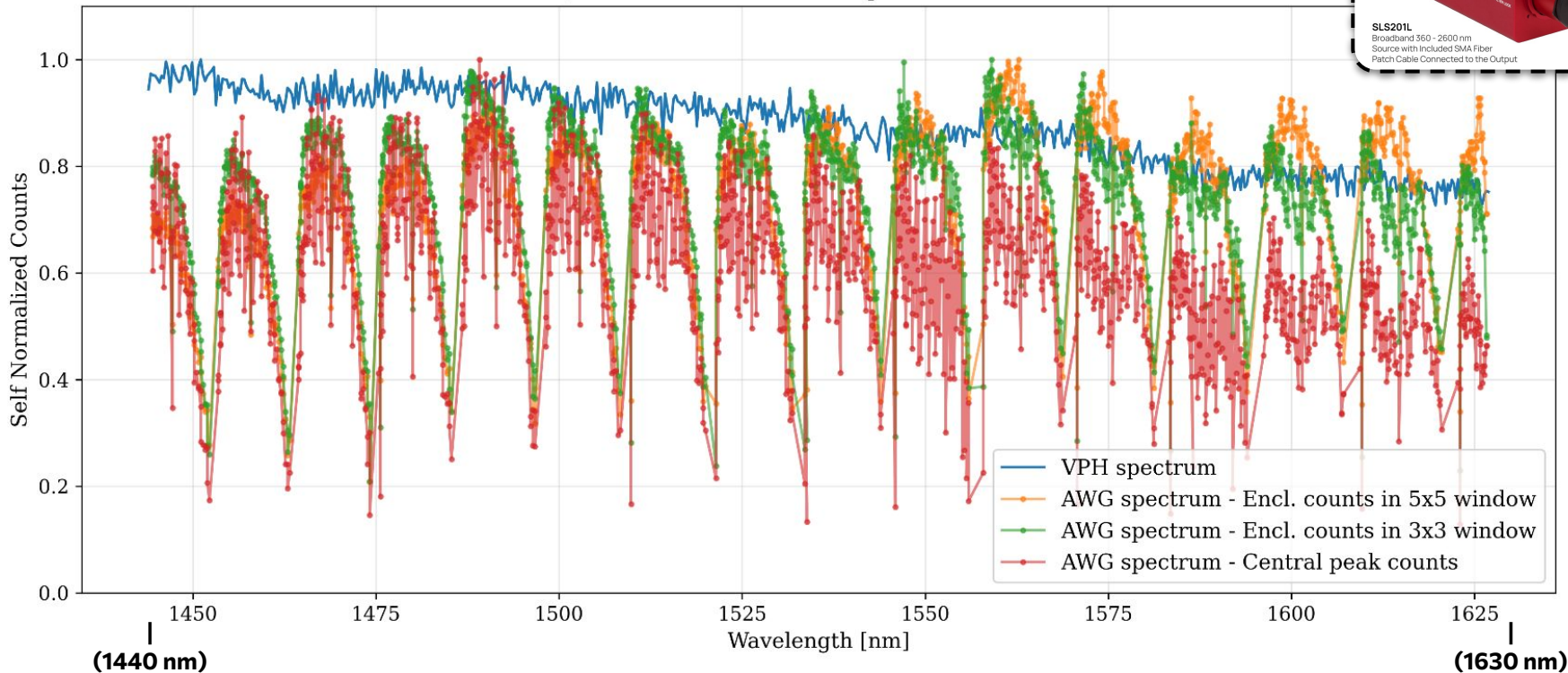

First extraction of AWG spectra: First light with Arcturus.

AWG spectrum of Arcturus extracted with bb flat spot positions - no WL cal

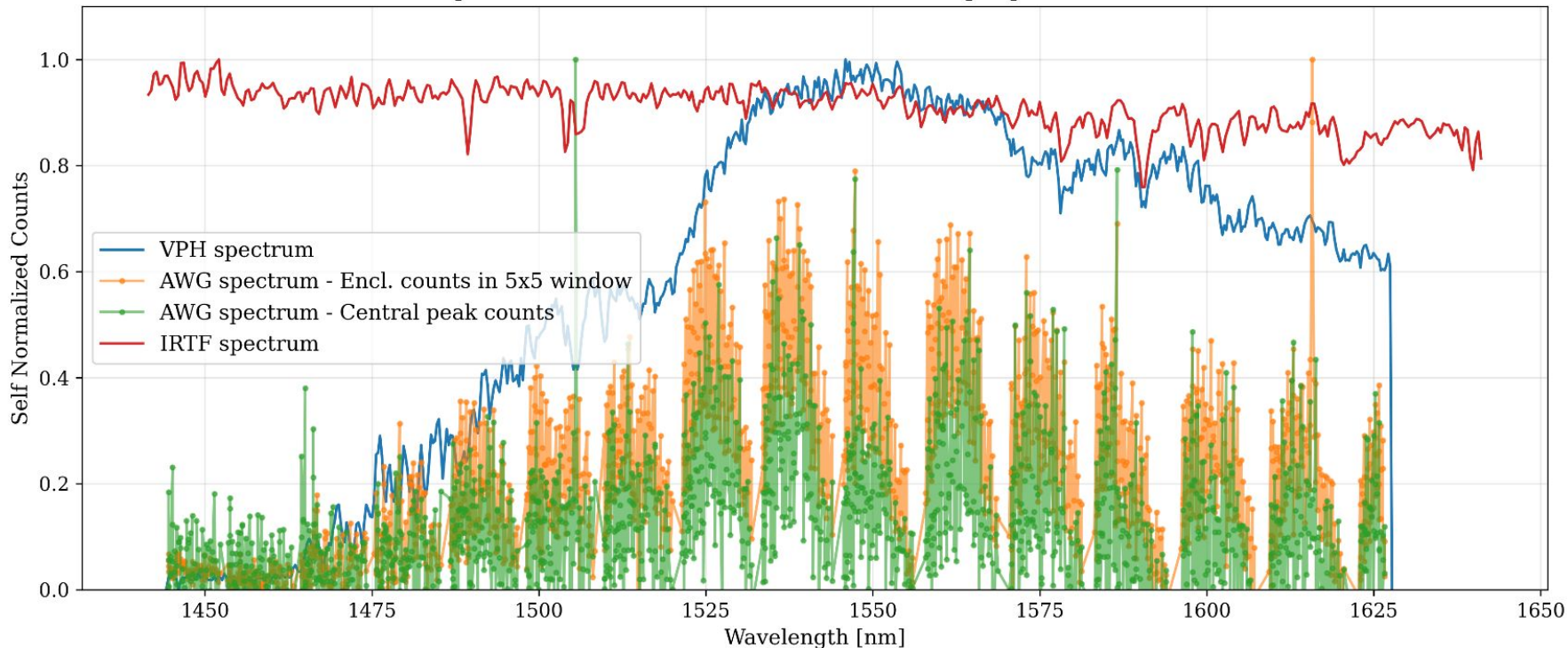

More on-sky testing! Bringing an improved prototype to Calern/AOC, Asiago/Ekarus and other AO capable facilities.

- Cleaner spectral extraction + wavelength calibration & background subtraction.
- Comparison with existing spectra in catalogs (IRTF database).
- Instrument simulation.
- Study improvements for the prototype.
- Future experiments / chip designs involving AWGs and more!

1. Photonic H-band nulling spectro-interferometer

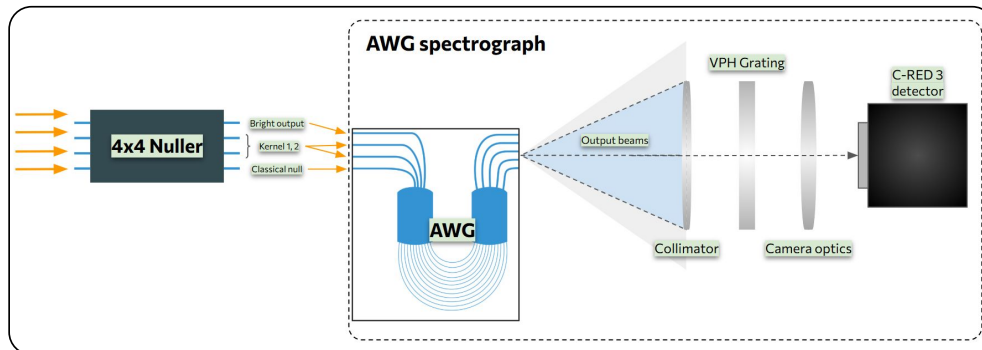

2. Achromatic phase shifter on a chip

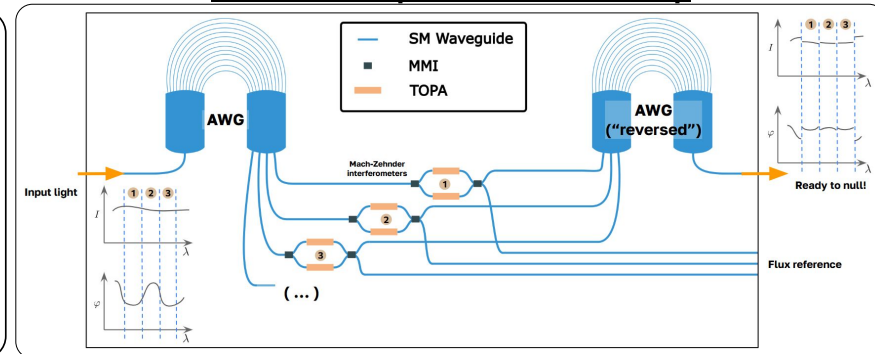

Thank you!

jcalderon@oca.eu

* We acknowledge funding from the project **COMPACT-SPECTROGRAPHS** financed by the **ANR program PEPR Origins (ANR-22-EXOR-0006)**. This work was supported by the **Wilf Family Discovery Fund in Space and Planetary Science**, funded by the Wilf Family Foundation, as well as the support from Keck Institute for Space Studies at Caltech.

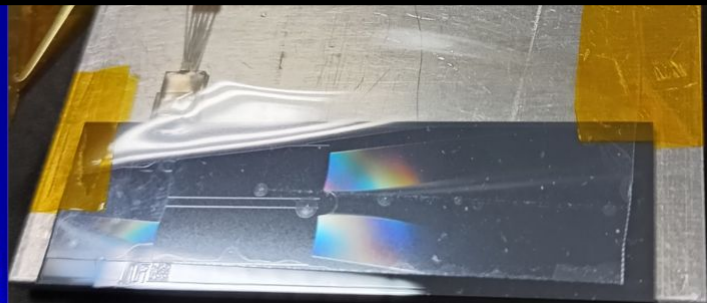
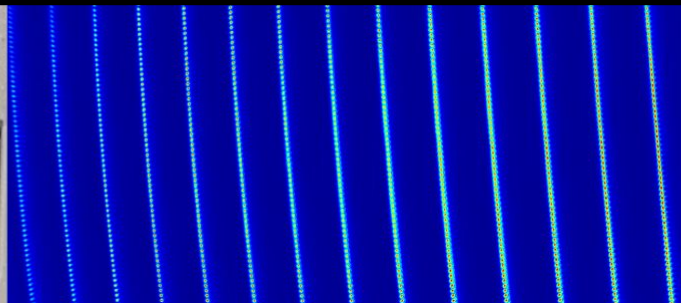
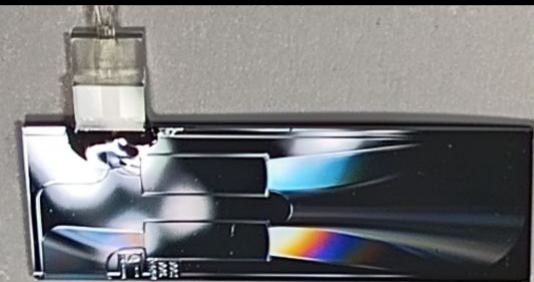

Bonus

Characterization of AWGs

2 experimental setups to characterize the chips (Master's thesis work in 2025):

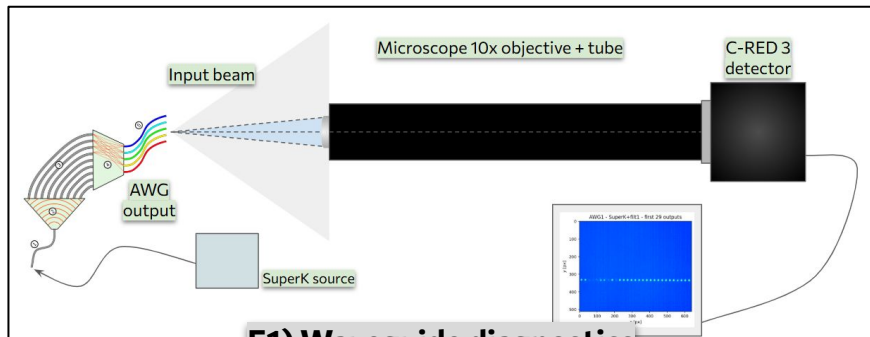

E1) Waveguide diagnostics

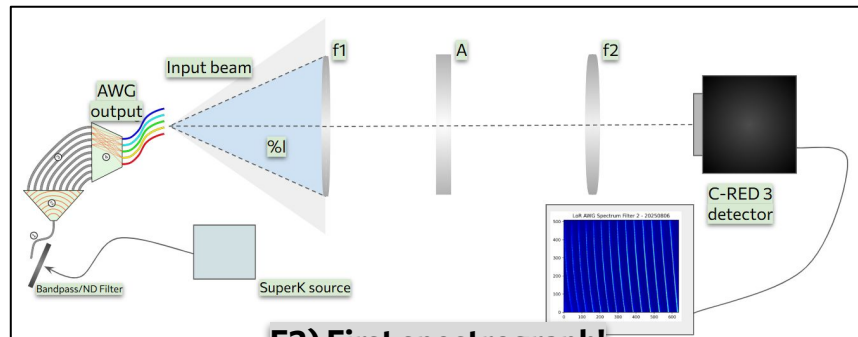
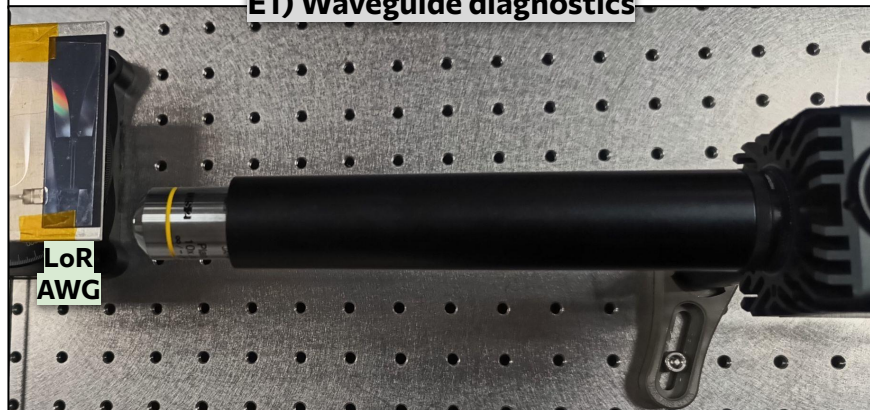

E2) First spectrograph!

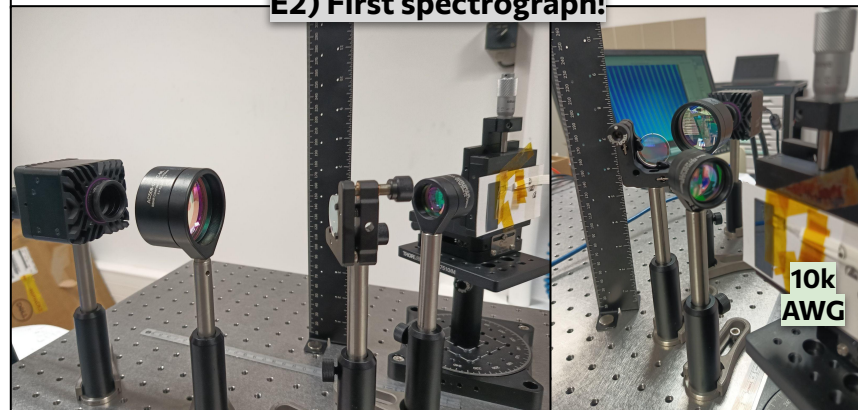

Output diagnostics

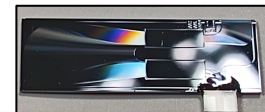

Emerald chip: 145 outputs

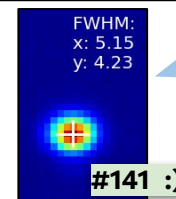
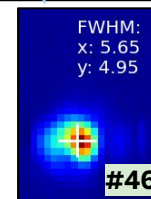
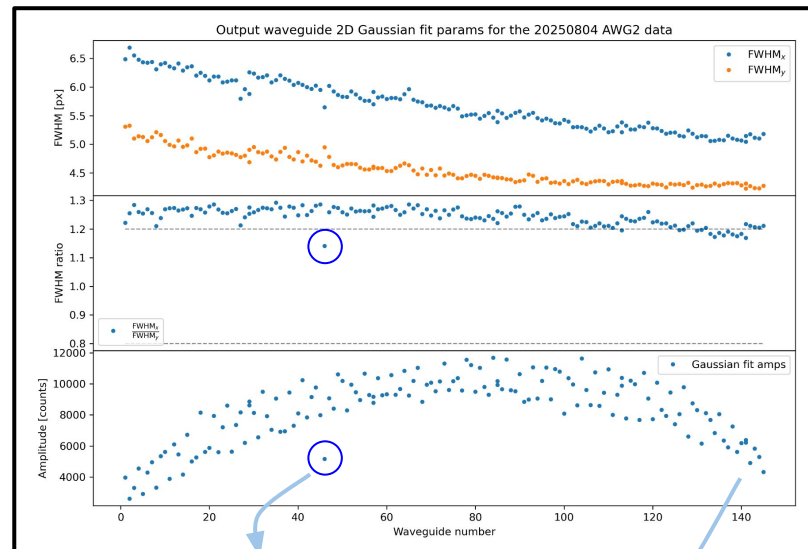
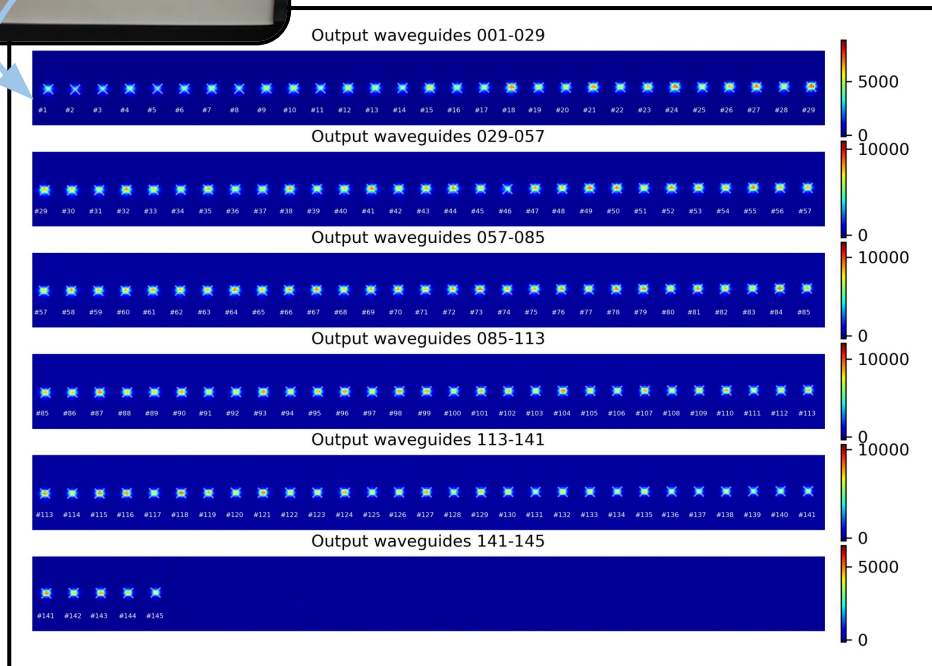
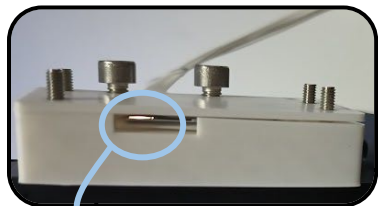

First in-lab spectra with superK laser

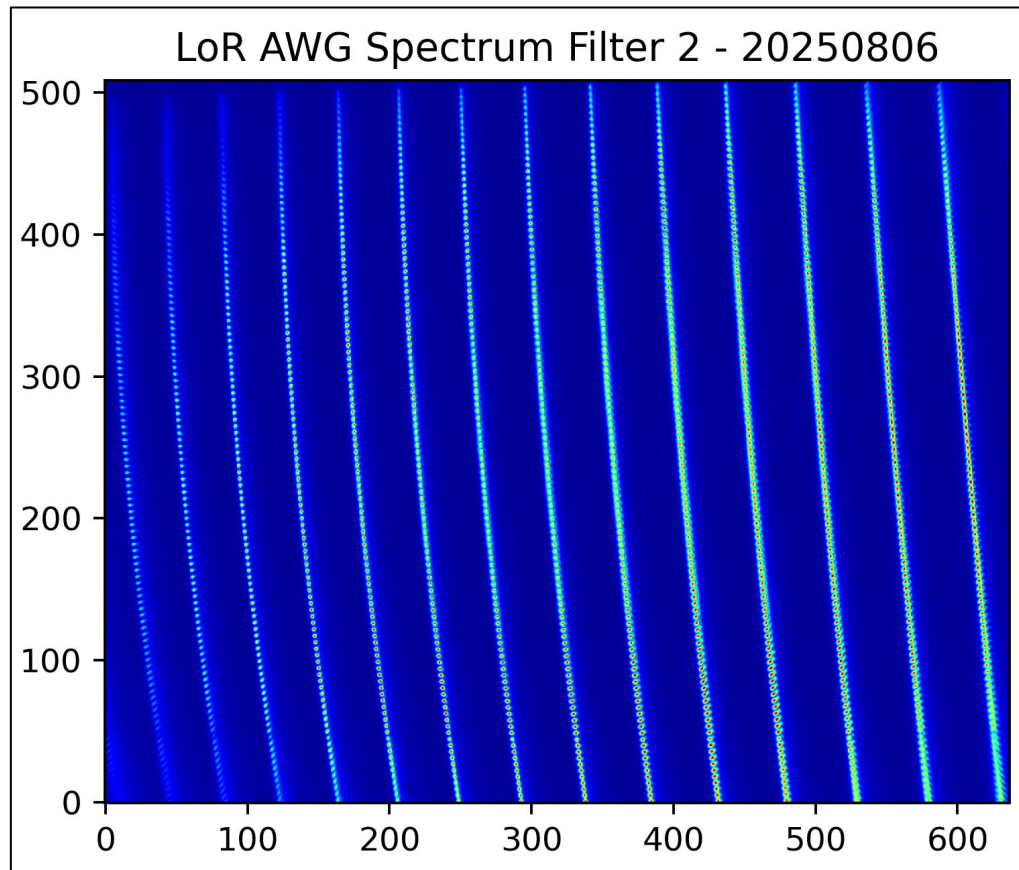
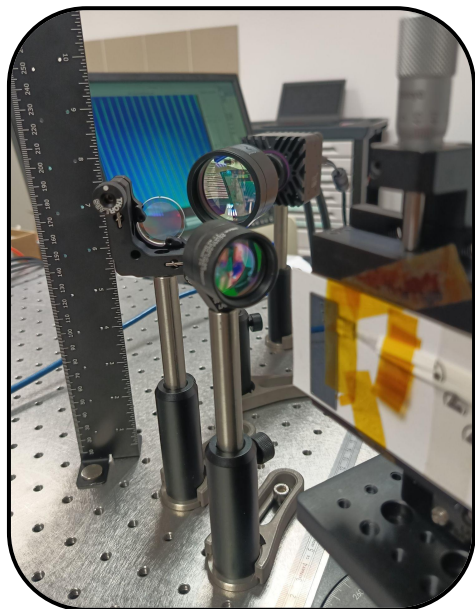
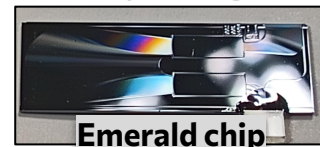

Multiple input tests

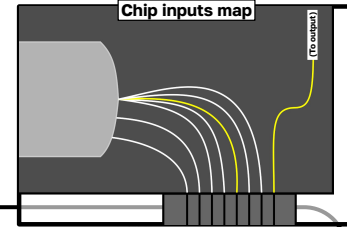

Input 01

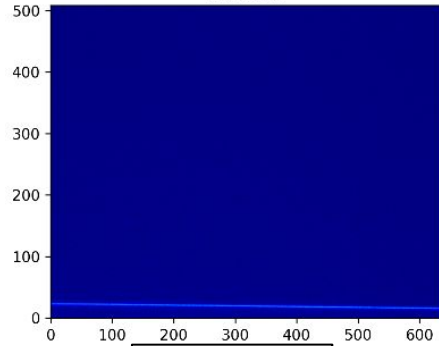

01) Straight-through

Input 02

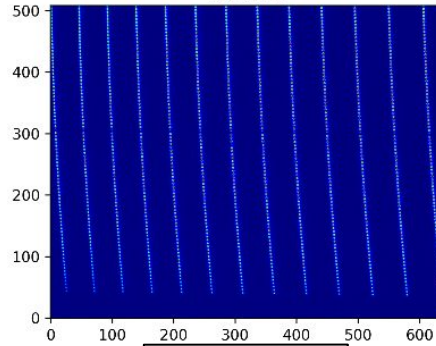

02) AWG - On-axis inj.

Input 03

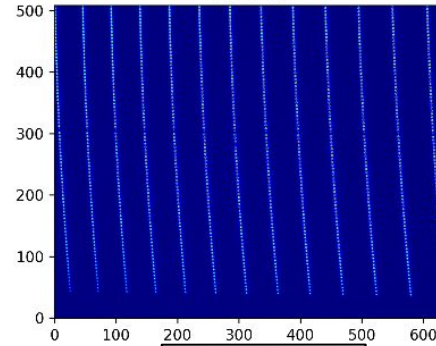

03) AWG - On-axis inj.

Input 04

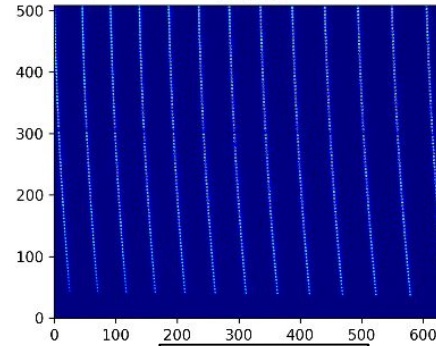

04) AWG - On-axis inj.

05) AWG - On-axis inj.

Input 05

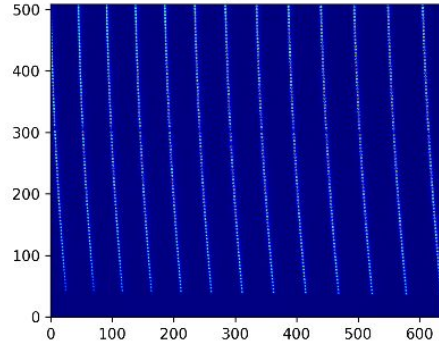

06) AWG - On-axis inj.

Input 06

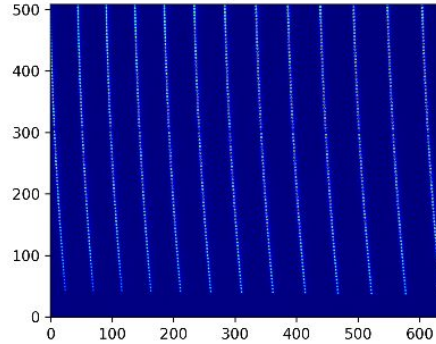

07) AWG - Off-axis inj. (1 FSR offset)

Input 07

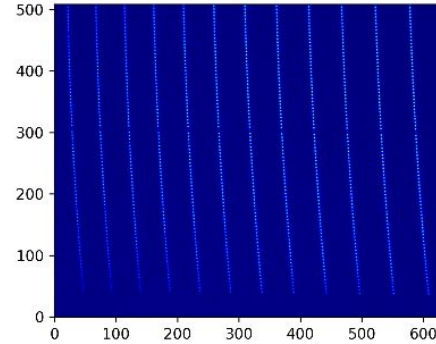

08) AWG - Highly off-axis inj. (no signal)

Input 08

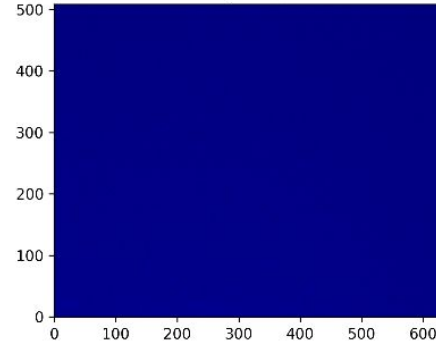

Arc06: Coadded-Dedarkened cubes (20s each) for input01 spectra of Arcturus 20260225

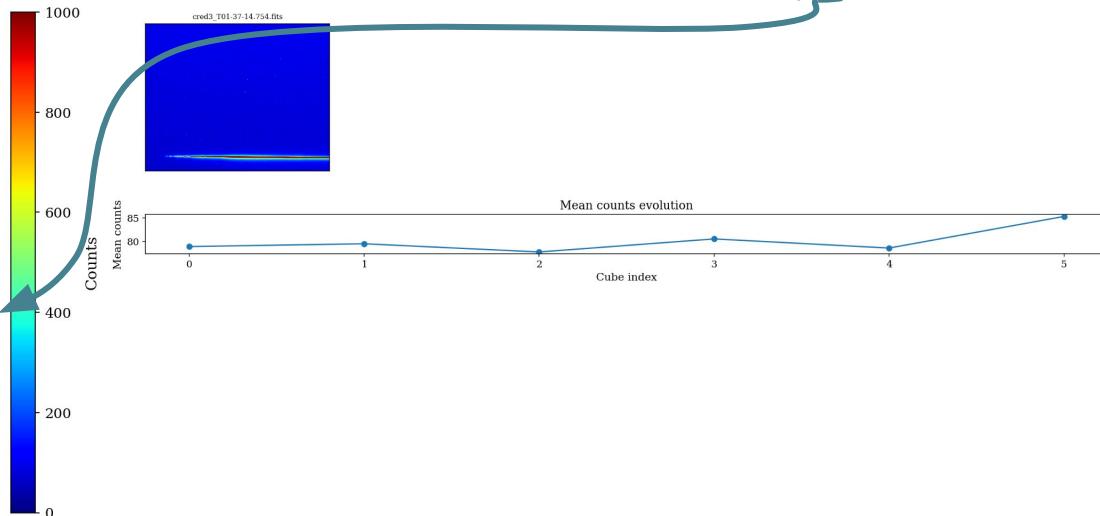
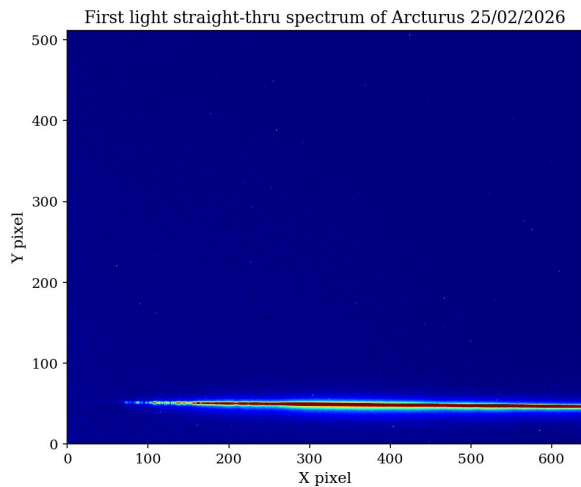
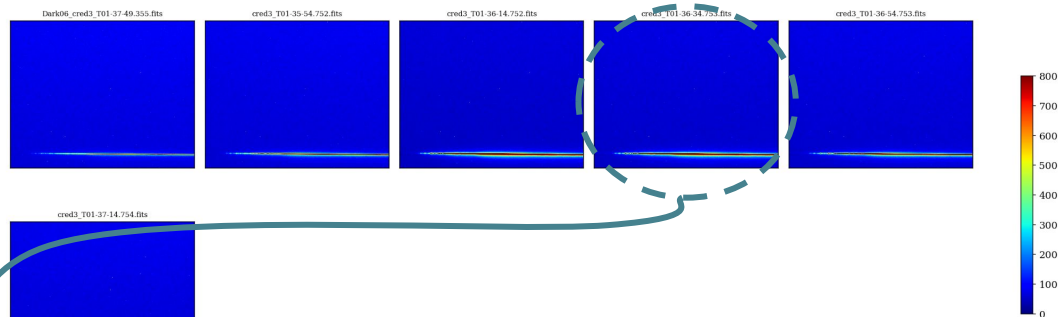

Input01 spectrum: Betelgeuse

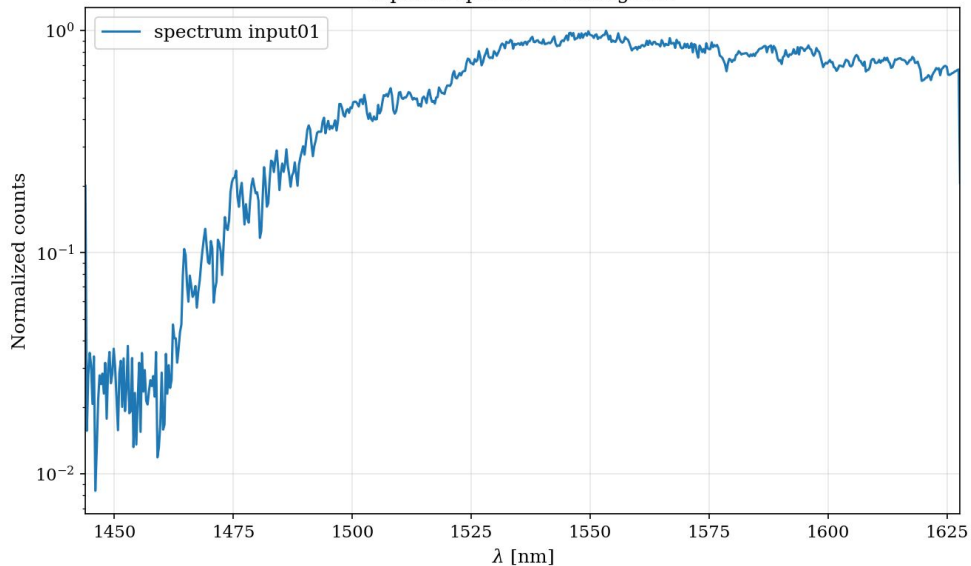

Input01 spectrum: Alcor

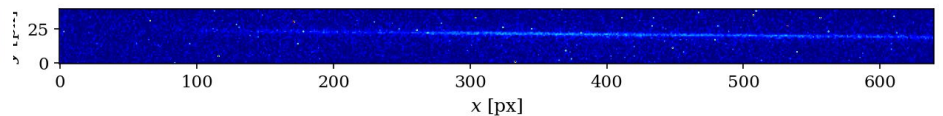
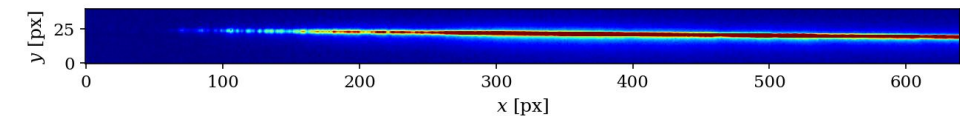
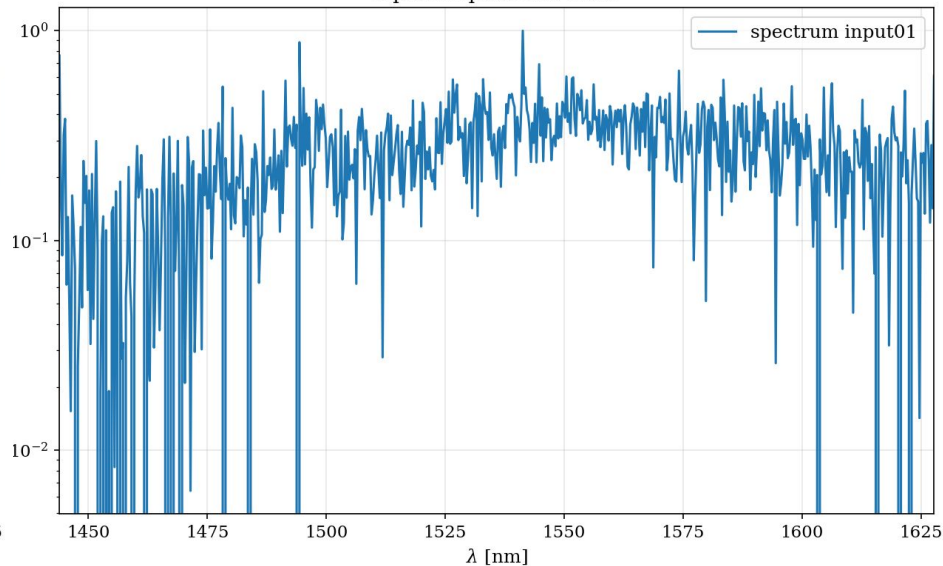

AWG First light: 25/02/2026

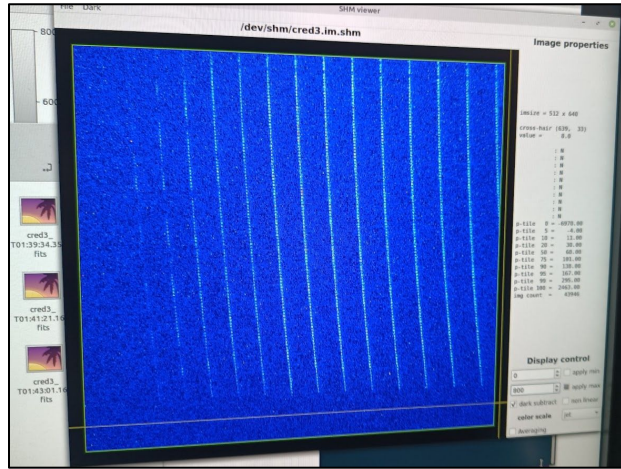

Coadded-Dedarkened cubes (20s each) for input04 spectra of Arcturus 20260225

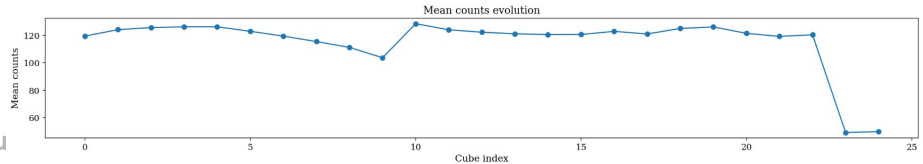
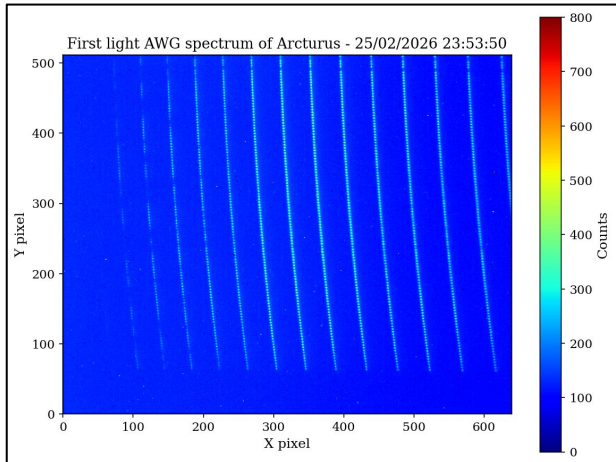
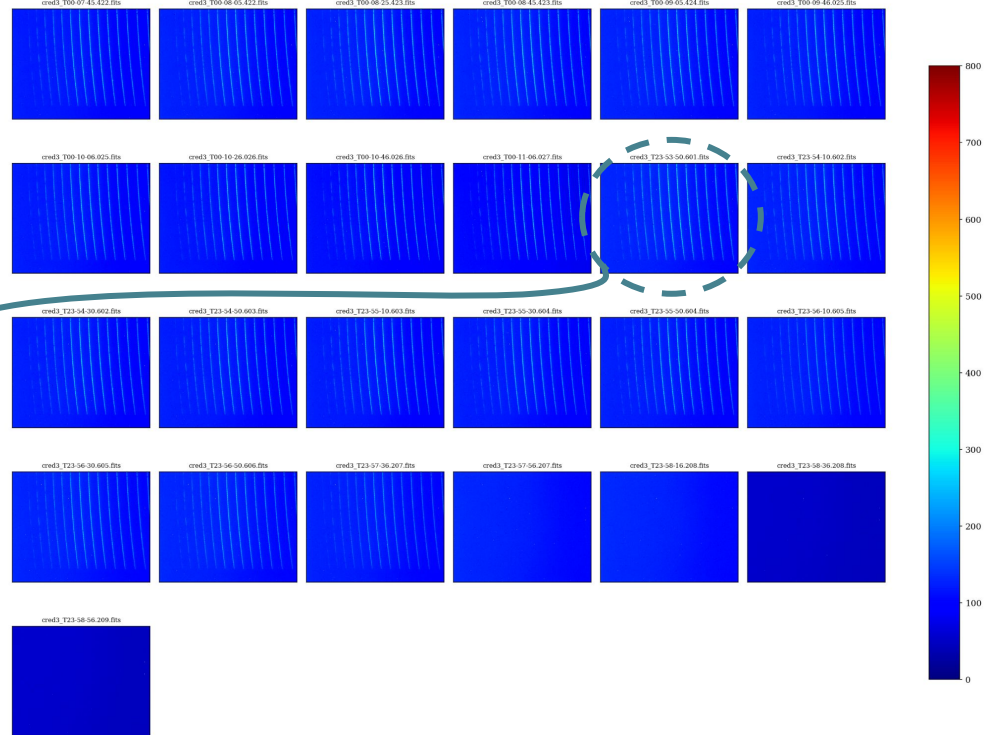

Night 1 attempts at Betelgeuse



Night 3 Betelgeuse nicer SNR :)

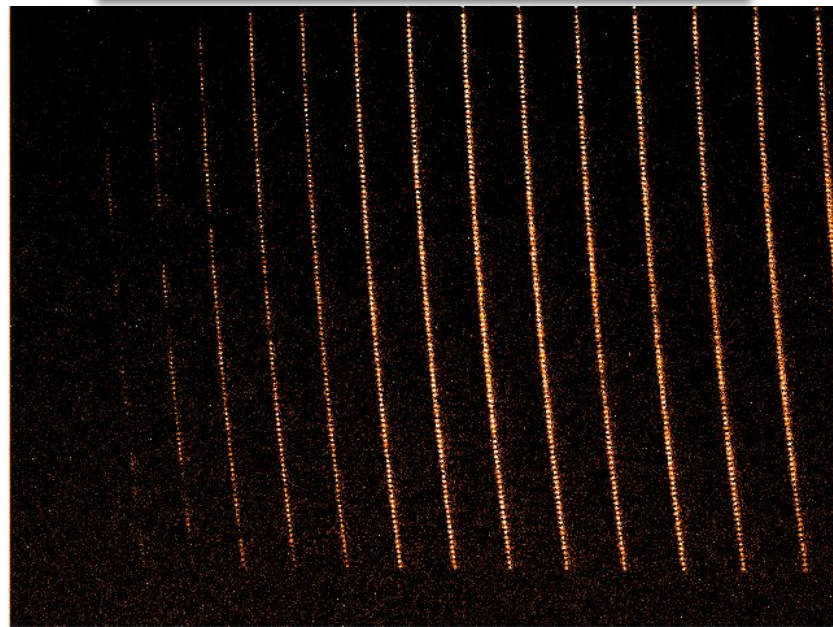

Wavelength calibration: Straight through (no AWG)

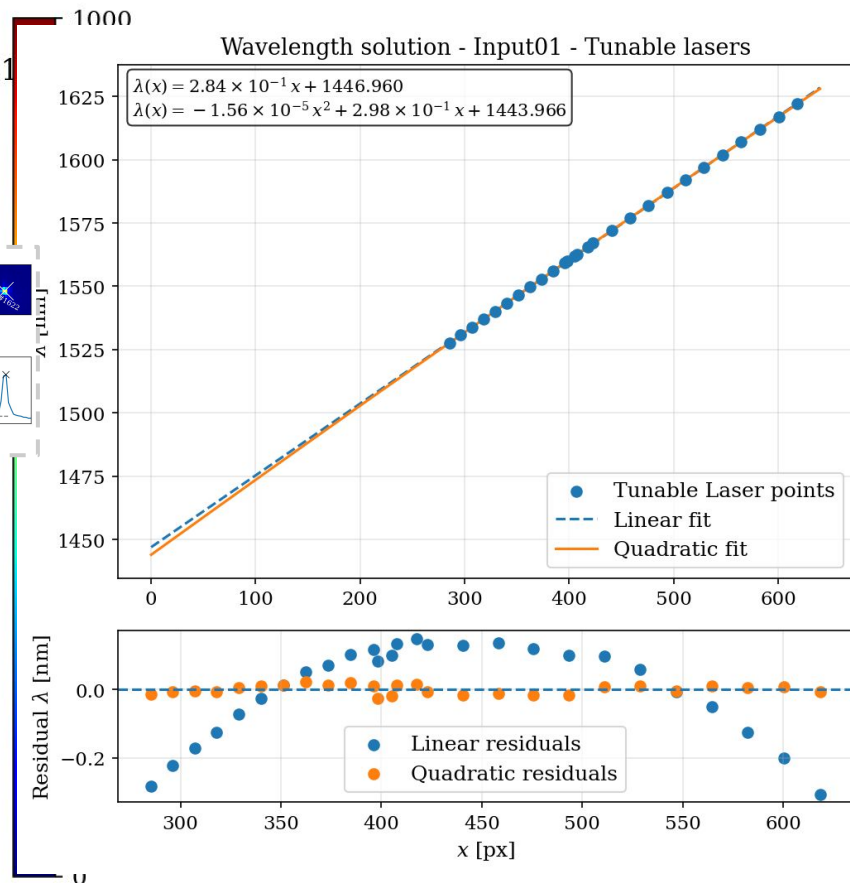
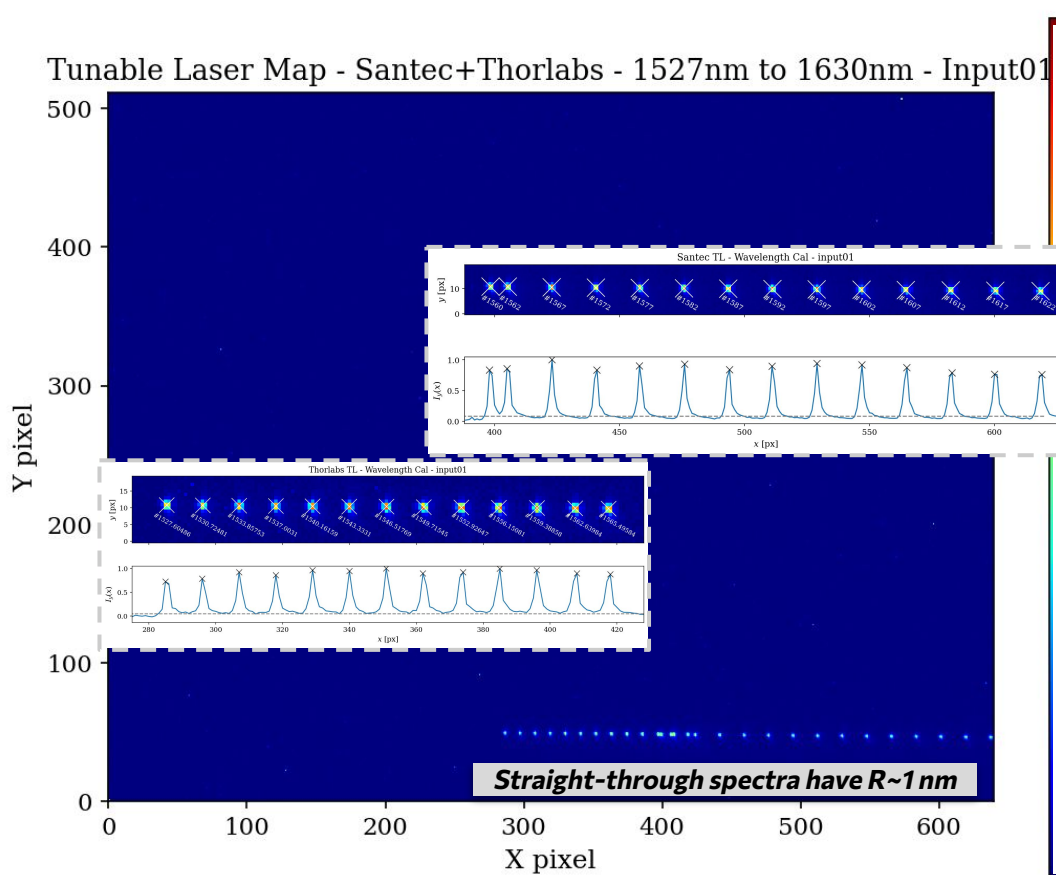

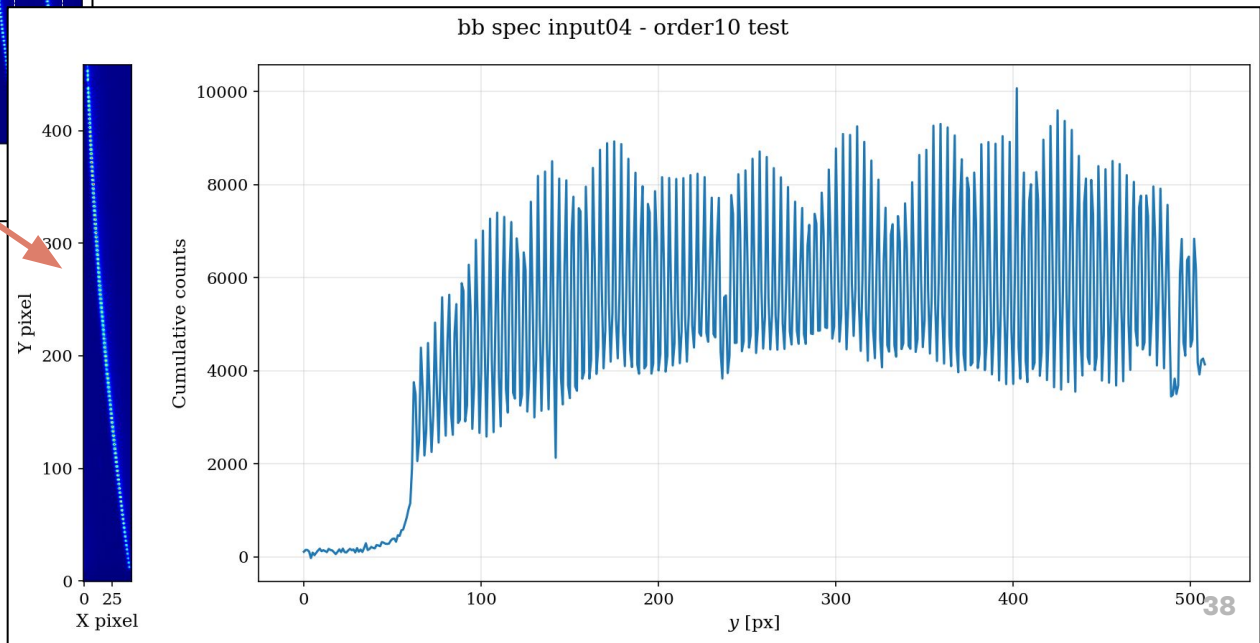
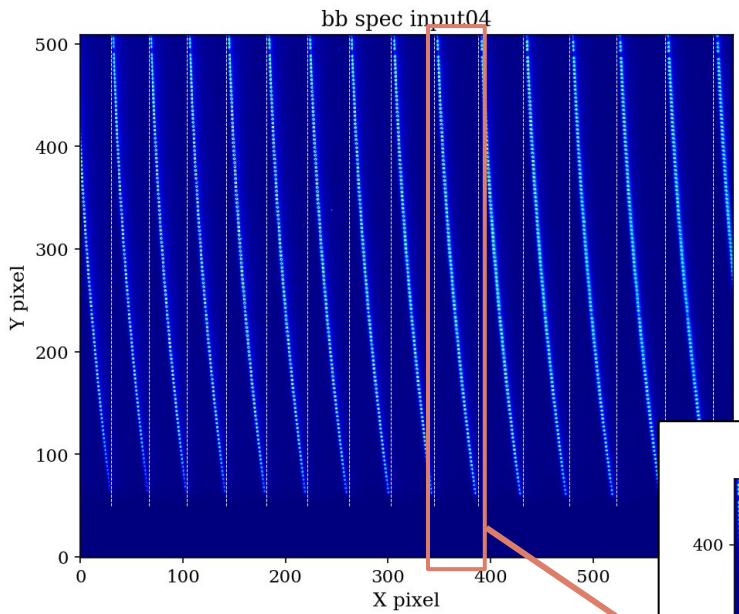

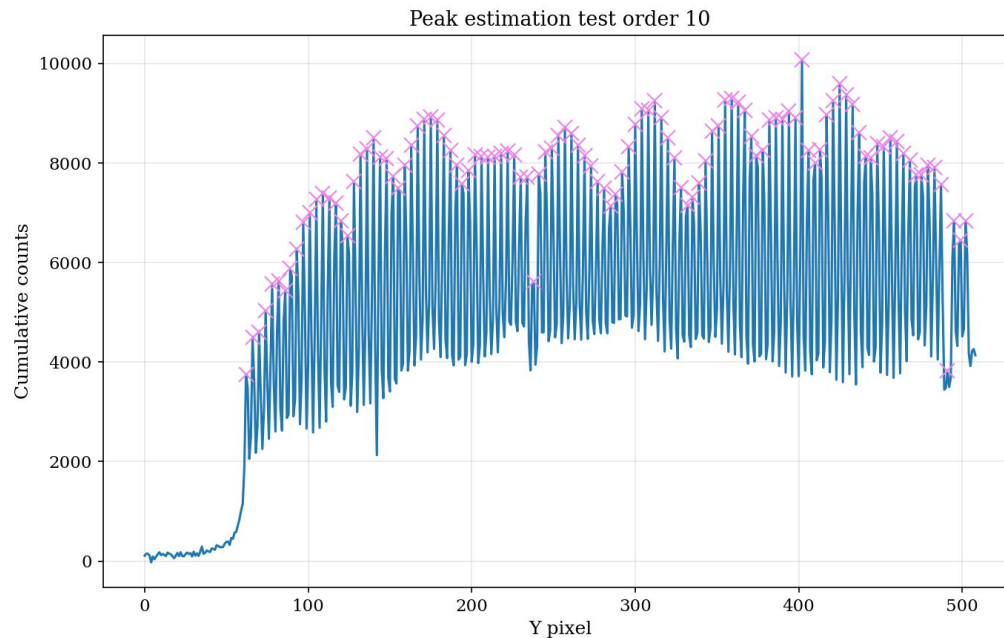
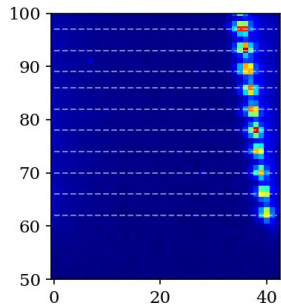

AWG spectrum - bb source

Y pixel

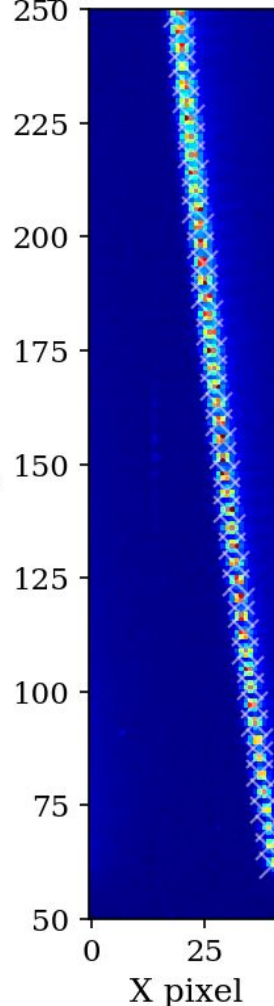

X pixel

Effects of using a different window size around the spot

AWG spectrum - broadband source

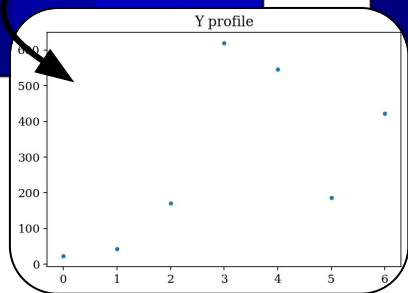
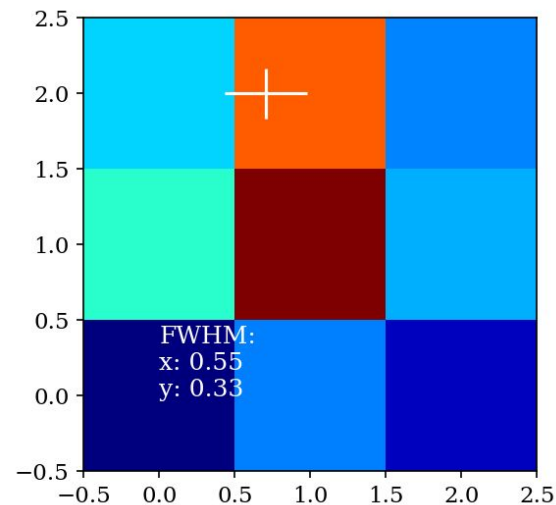
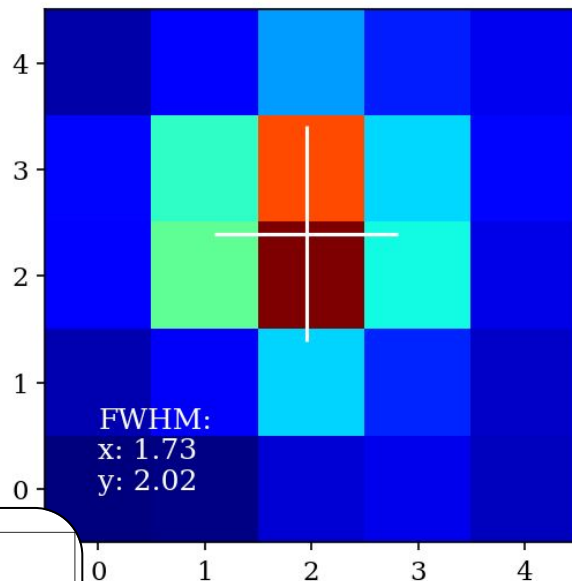
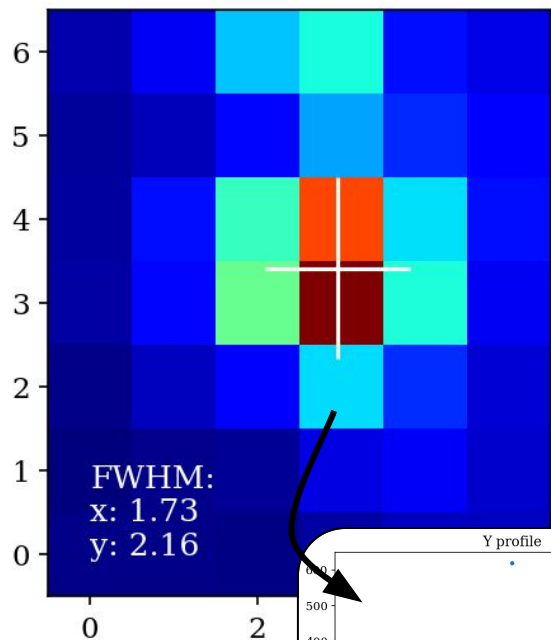

Spectrum of a single order - first extraction

Spot finder Ord10

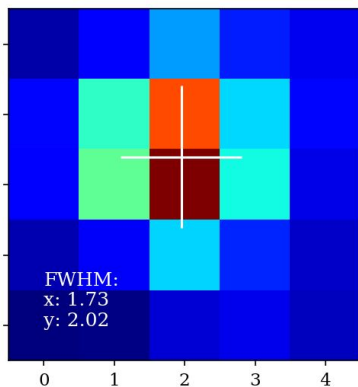
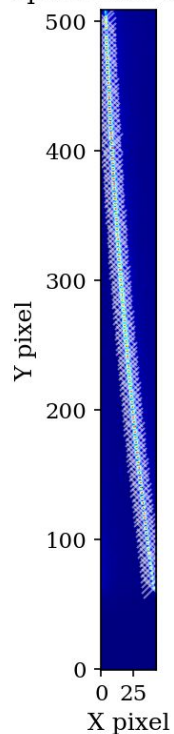

First extraction AWG Order10 (~1555nm) spectrum

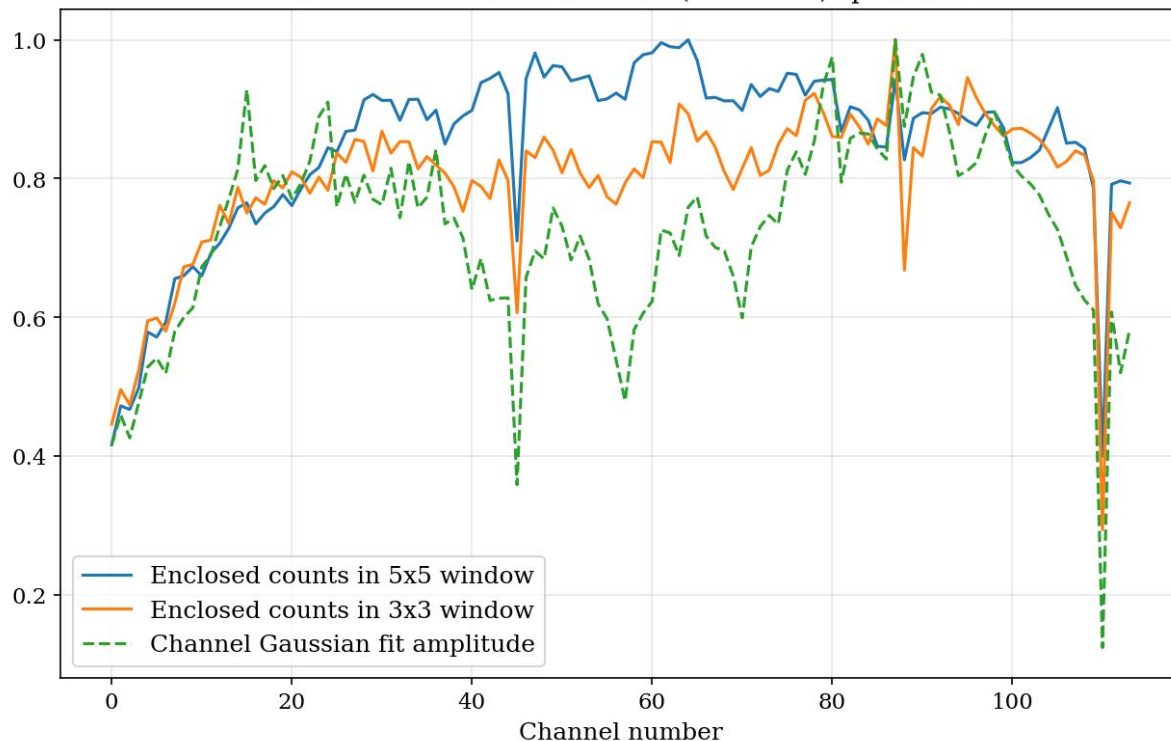

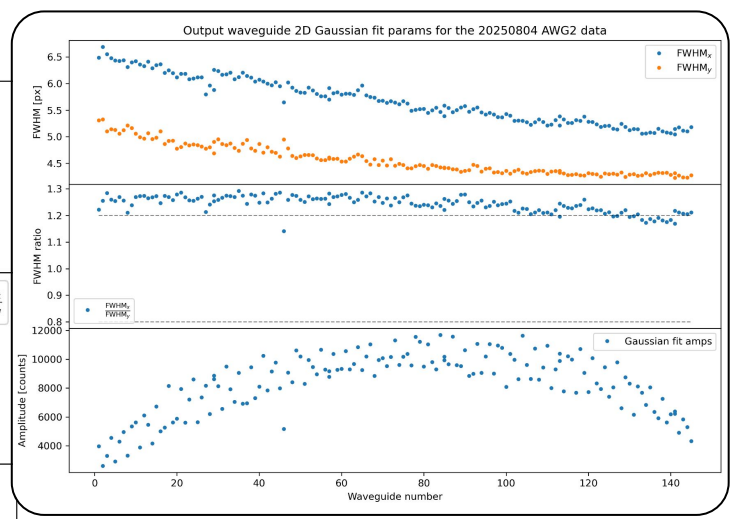
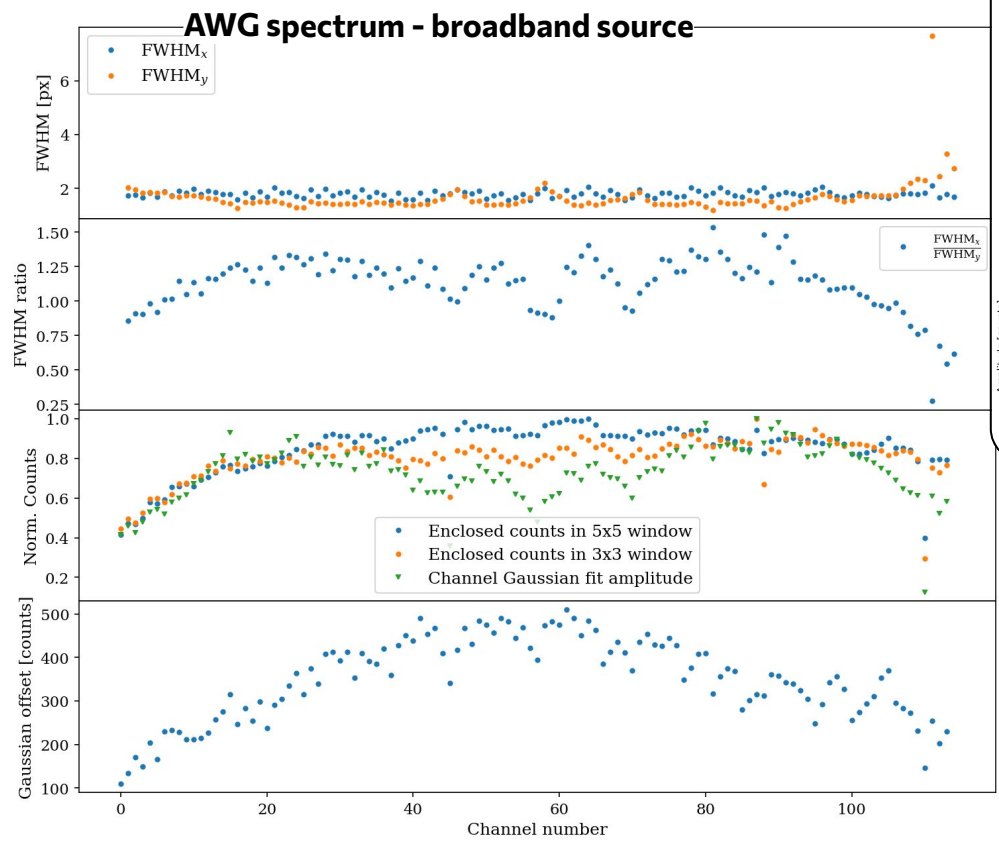
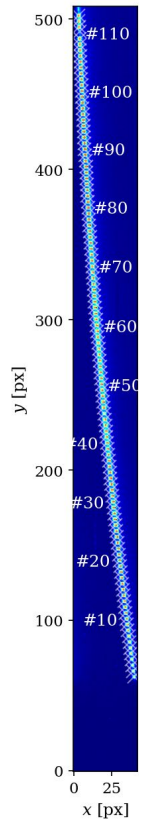
AWG spectrum - broadband source



Throwback to the first characterisation of the chip in Aug/2025

The AWG spectra are kinda tricky to analyze

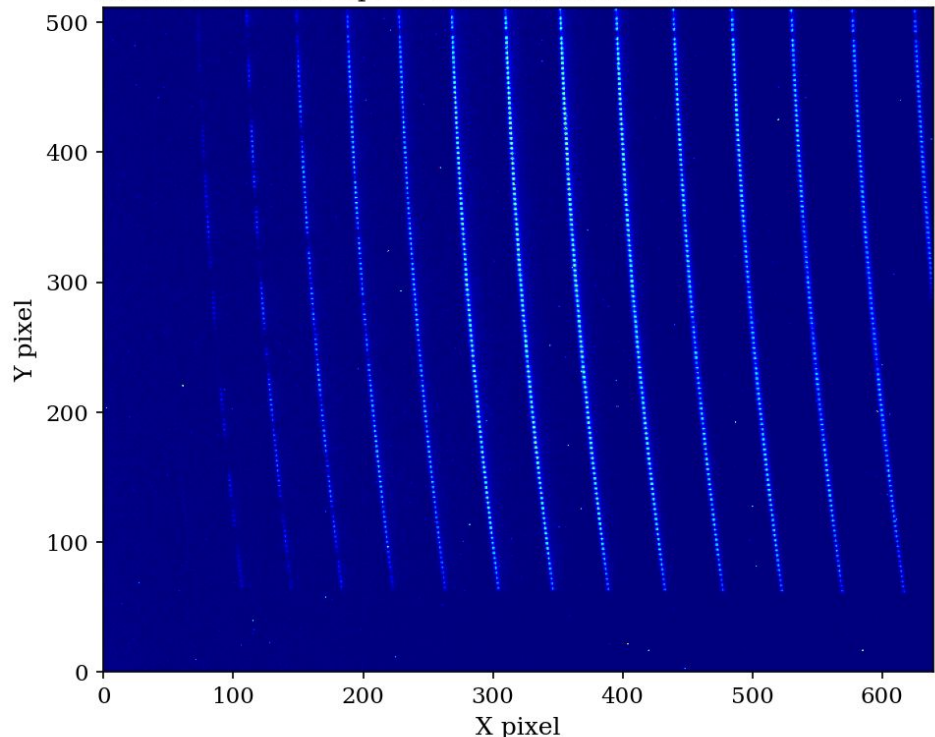
Mediancorr. AWG spectrum of Arcturus - 26/02/2026 00-08-95



Spectral Resolution: $R=18800$ at $\lambda=1562$ nm
($\Delta\lambda$ between 2 adjacent waveguides ~ 0.083 nm)

Tunable Laser Map - Santec+Thorlabs - 1527nm to 1630nm - Input0

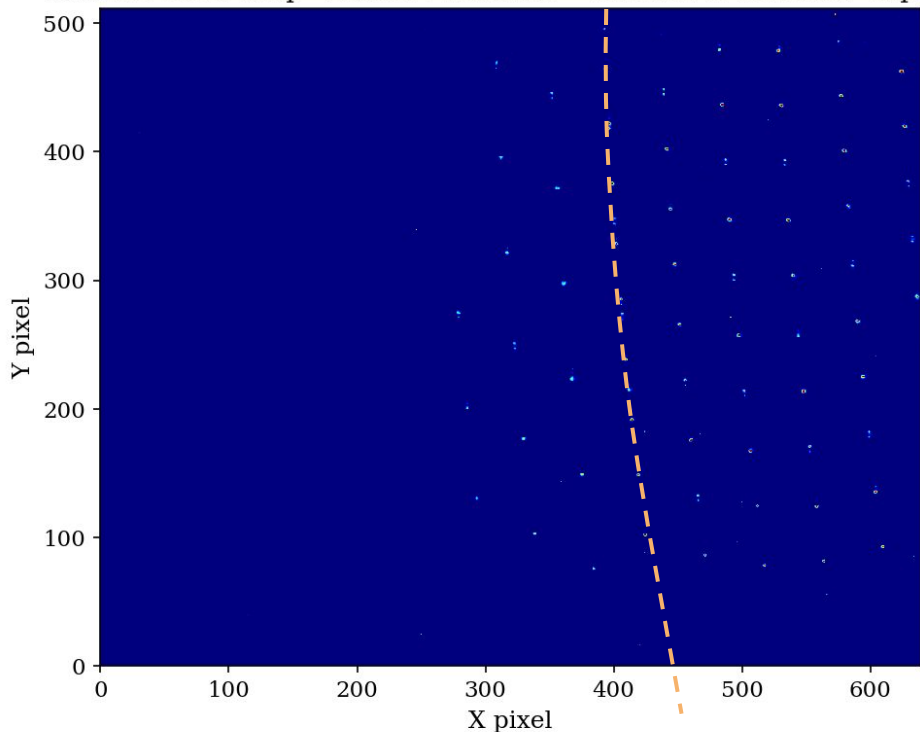

Spectral coverage: 1444 nm to 1630 nm

Lab vs on-sky

Noisy data is making challenging to extract a clean spectrum

bb spec input04 - order10 test

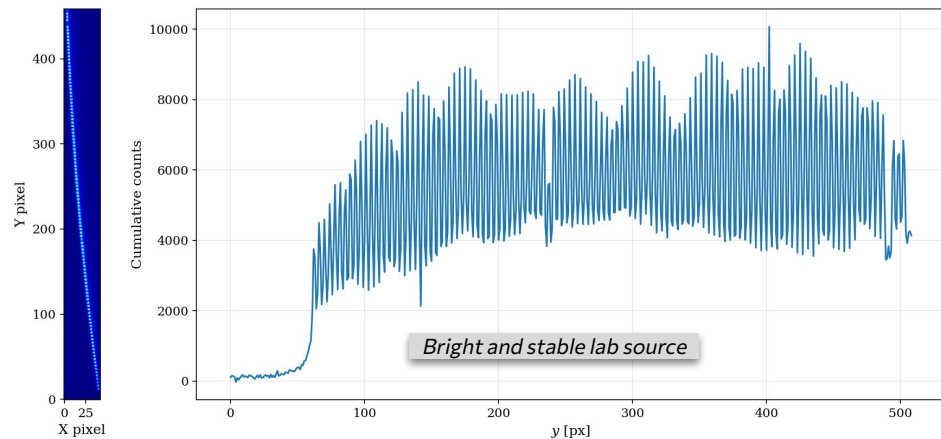

Betelgeuse spec input04 - order5 test

